

RYOBI®

XD-180

GB OWNER'S OPERATING MANUAL

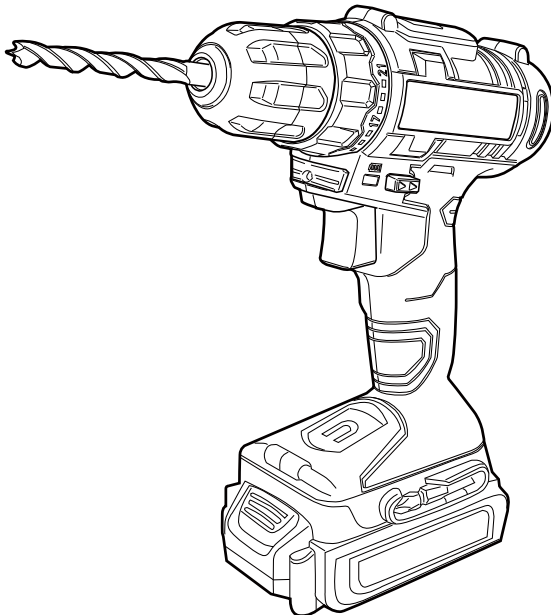

CE

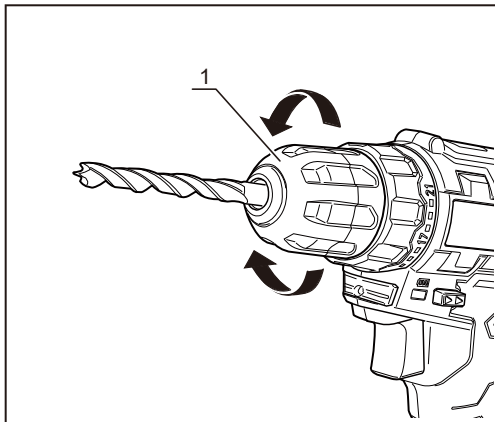
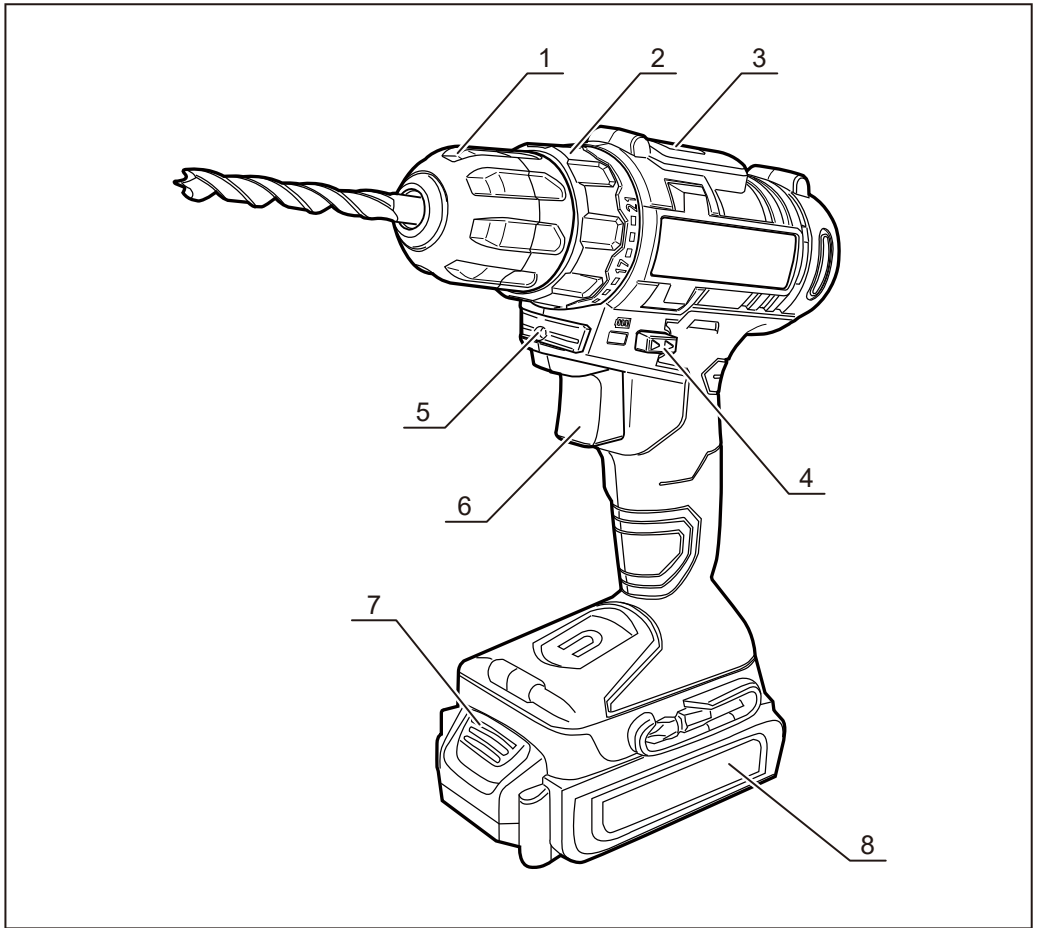

1

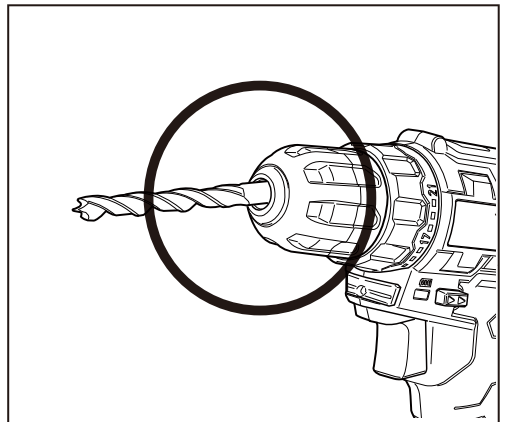

2

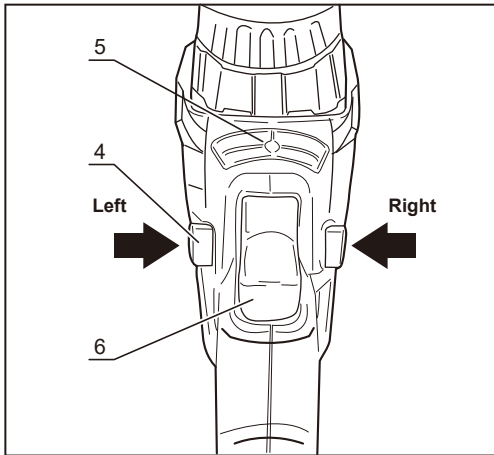

3

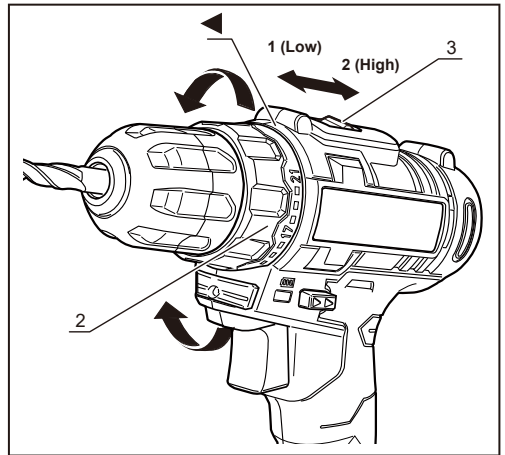

4

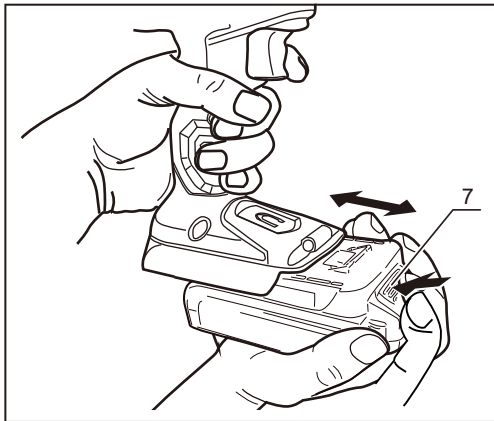

5

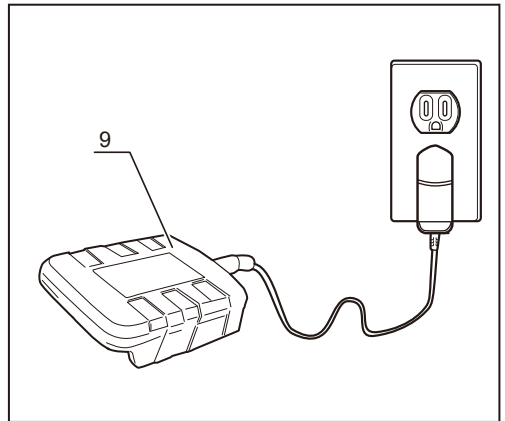

6

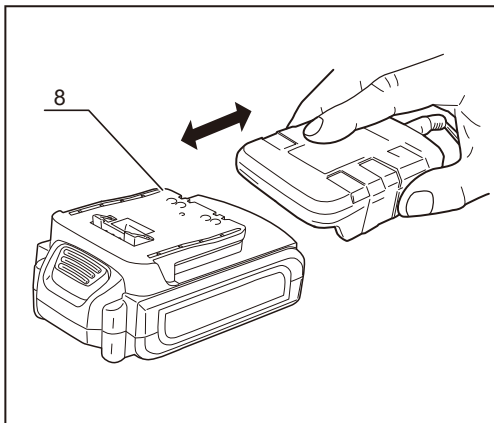

7

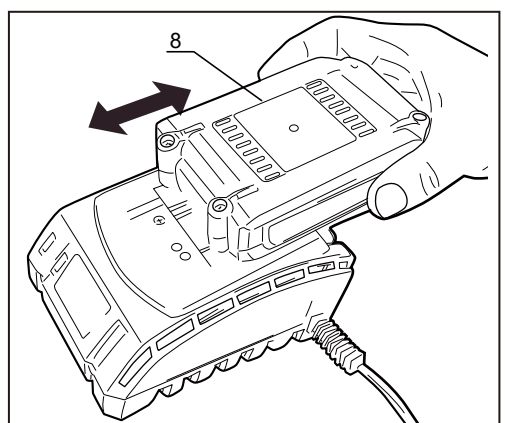

8

THANK YOU FOR BUYING A RYOBI PRODUCT.

To ensure your safety and satisfaction, carefully read through this OWNER'S MANUAL before using the product.

General Power Tool Safety Warnings

⚠ WARNING! Read all safety warnings and all instructions.

Failure to follow the warnings and instructions may result in electric shock, fire and/or serious injury.

Save all warnings and instructions for future reference.

The term "power tool" in the warnings refers to your mains-operated (corded) power tool or battery-operated (cordless) power tool.

1) Work area safety

- a) **Keep work area clean and well lit.** Cluttered or dark areas invite accidents.
- b) **Do not operate power tools in explosive atmospheres, such as in the presence of flammable liquids, gases or dust.** Power tools create sparks which may ignite the dust or fumes.
- c) **Keep children and bystanders away while operating a power tool.** Distractions can cause you to lose control.

2) Electrical safety

- a) **Power tool plugs must match the outlet. Never modify the plug in any way. Do not use any adapter plugs with earthed (grounded) power tools.** Unmodified plugs and matching outlets will reduce risk of electric shock.
- b) **Avoid body contact with earthed or grounded surfaces such as pipes, radiators, ranges and refrigerators.** There is an increased risk of electric shock if your body is earthed or grounded.
- c) **Do not expose power tools to rain or wet conditions.** Water entering a power tool will increase the risk of electric shock.
- d) **Do not abuse the cord. Never use the cord for carrying, pulling or unplugging the power tool. Keep cord away from heat, oil, sharp edges or moving parts.** Damaged or entangled cords increase the risk of electric shock.
- e) **When operating a power tool outdoors, use an extension cord suitable for outdoor use.** Use of a cord suitable for outdoor use reduces the risk of electric shock.
- f) **If operating a power tool in a damp location is unavoidable, use a residual current device (RCD) protected supply.** Use of an RCD reduces the risk of electric shock.

3) Personal safety

- a) **Stay alert, watch what you are doing and use common sense when operating a power tool. Do not use a power tool while you are tired or under the influence of drugs, alcohol or medication.** A moment of inattention while operating power tools may result in serious personal injury.
- b) **Use personal protective equipment. Always wear eye protection.** Protective equipment such as dust mask, non-skid safety shoes, hard hat, or hearing protection used for appropriate conditions will reduce personal injuries.
- c) **Prevent unintentional starting. Ensure the switch is in the off-position before connecting to power source and/or battery pack, picking up or carrying the tool.** Carrying power tools with your finger on the switch or energising power tools that have the switch on invites accidents.
- d) **Remove any adjusting key or wrench before turning the power tool on.** A wrench or a key left attached to a rotating part of the power tool may result in personal injury.
- e) **Do not overreach. Keep proper footing and balance at all times.** This enables better control of the power tool in unexpected situations.

- f) **Dress properly. Do not wear loose clothing or jewelry. Keep your hair, clothing and gloves away from moving parts.** Loose clothes, jewellery or long hair can be caught in moving parts.
- g) **If devices are provided for the connection of dust extraction and collection facilities, ensure these are connected and properly used.** Use of dust collection can reduce dust-related hazards.

4) Power tool use and care

- a) **Do not force the power tool. Use the correct power tool for your application.** The correct power tool will do the job better and safer at the rate for which it was designed.
- b) **Do not use the power tool if the switch does not turn it on and off.** Any power tool that cannot be controlled with the switch is dangerous and must be repaired.
- c) **Disconnect the plug from the power source and/or the battery pack from the power tool before making any adjustments, changing accessories, or storing power tools.** Such preventive safety measures reduce the risk of starting the power tool accidentally.
- d) **Store idle power tools out of the reach of children and do not allow persons unfamiliar with the power tool or these instructions to operate the power tool.** Power tools are dangerous in the hands of untrained users.
- e) **Maintain power tools. Check for misalignment or binding of moving parts, breakage of parts and any other condition that may affect the power tool's operation.** If damaged, have the power tool repaired before use. Many accidents are caused by poorly maintained power tools.
- f) **Keep cutting tools sharp and clean.** Properly maintained cutting tools with sharp cutting edges are less likely to bind and are easier to control.
- g) **Use the power tool, accessories and tool bits etc. in accordance with these instructions, taking into account the working conditions and the work to be performed.** Use of the power tool for operations different from those intended could result in a hazardous situation.

5) Battery tool use and care

- a) **Recharge only with the charger specified by the manufacturer.** A charger that is suitable for one type of battery pack may create a risk of fire when used with another battery pack.
- b) **Use power tools only with specifically designated battery packs.** Use of any other battery packs may create a risk of injury and fire.
- c) **When battery pack is not in use, keep it away from other metal objects, like paper clips, coins, keys, nails, screws or other small metal objects, that can make a connection from one terminal to another.** Shorting the battery terminals together may cause burns or a fire.
- d) **Under abusive conditions, liquid may be ejected from the battery; avoid contact. If contact accidentally occurs, flush with water. If liquid contacts eyes, additionally seek medical help.** Liquid ejected from the battery may cause irritation or burns.

6) Service

- a) **Have your power tool serviced by a qualified repair person using only identical replacement parts.** This will ensure that the safety of the power tool is maintained.

INSTRUCTIONS FOR SAFE HANDLING

1. Make sure that the tool is only connected to the voltage marked on the name plate.
 2. Never use the tool if its cover or any bolts are missing. If the cover or bolts have been removed, replace them prior to use. Maintain all parts in good working order.
 3. Always secure the tool when working in elevated positions.
 4. Never touch the blade, drill bit, grinding wheel or other moving parts during use.
 5. Never start the tool when its rotating component is in contact with the work piece.
 6. Never lay the tool down before its moving parts have come to a complete stop.
- 7. ACCESSORIES :**
The use of accessories or attachments other than those recommended in this manual might present a hazard.
- 8. REPLACEMENT PARTS :**
When servicing use only identical replacement parts.

CORDLESS DRIVER DRILL SAFETY PRECAUTIONS

1. Be aware that since this tool does not have to be plugged into an electrical outlet, it is always in operating condition.
2. First, charge the battery.
3. Be sure the battery holder is securely snapped in place.
4. When not in use, lock the trigger.
5. When operating at high places, be aware of things below you.
6. Before drilling into walls, ceilings or floors, ensure that there are no concealed power cables inside.

DISPOSAL OF THE EXHAUSTED BATTERY

Li-ion batteries must be recycled.
Take the battery to the shop from which it was purchased as soon as the post-charging battery life becomes too short for practical use.
Do not discard the exhausted battery.

DESCRIPTION

- | | |
|----------------------------|-----------------------|
| 1. Keyless chuck | 6. Trigger |
| 2. Torque adjustment cap | 7. Battery clip |
| 3. Speed selector | 8. Battery pack |
| 4. Forward/ Reverse switch | 9. Charging connector |
| 5. LED work light | |

SPECIFICATIONS

Battery	18V, 1,500mAh Li-ion
Chuck capacity	10mm
No load speed	0-400/ 0-1500min ⁻¹
Max torque	20Nm
Drilling capacity	steel: 8mm
	wood: 19mm
Charger type.....	JLH08215037G
Clutch position	21 + 1
Charging time	3-5hours
Net weight	1.3kg

APPLICATIONS

- (Use only for the purposes listed below.)
1. Drilling wood, ceramics, plastics, fiberglass, metal and concrete.
 2. Driving and removing machine screws, wood screws, tapping screws etc.

KEYLESS CHUCK AND MOUNTING THE BIT (Fig. 1)

This tool comes equipped with a keyless chuck to easily mount the bit.
Insert the bit into the chuck as far as it will go and rotate the chuck clockwise to securely tighten the bit.
The bit can be removed by turning the chuck counterclockwise.

WARNING! Make sure to insert the drill bit straight into the chuck jaws. Do not insert the drill bit into the chuck jaws at an angle then tighten (Fig. 2). This could cause the drill bit to be thrown from the drill, resulting in possible serious personal injury or damage to the chuck.

TRIGGER (Fig. 3)

This tool is started and stopped by depressing and releasing the trigger (6).
The drill speed is variable from 0 through 400 (Low speed position) or from 0 through 1,500 (High speed position) by controlling the trigger-squeezing force.

FORWARD/ REVERSE SWITCH (Fig. 3)

To change the direction of rotation, stop the tool by releasing the trigger and push the forward/ reverse switch (4) to the opposite side. When the reversing switch is set to the right position, the direction of rotation will be clockwise when viewed from the handle end of the drill. When the reversing switch is set to the left position, the direction of rotation will be counter-clockwise.
The trigger can be locked by positioning the reversing switch at the center. Lock the trigger whenever the tool is not in use.

LED WORK LIGHT (Fig. 3)

This tool is equipped with a LED work light (5) to illuminate the tip of a bit. The light turns on by depressing the trigger.

SPEED SELECTION (Fig. 4)

To match the task at hand, two rotation speeds **1** (low) and **2** (high) are featured. The speed can only be changed when the tool is at rest. The speed selector(3) is located on top of the housing.

FASTENING TORQUE ADJUSTMENT (Fig. 4)

This tool is equipped with a clutch which enables the fastening torque to be adjusted in 21 stages.
To use the tool in the screwdriver mode, set one of the numbers "1" to "21" indicated on the torque adjustment cap (2) to the marked (◀) on the top side of housing. The higher number on the torque adjustment cap, the greater the torque.
To use the tool in the drill mode, set the drill mark (⚙) on the torque adjustment cap to the point. The clutch does not operate when the tool is used in the drill mode.

CHARGING BATTERY PACK (Fig. 5, 6, 7, 8)

The battery pack (8) for the tool has been shipped in a low charge condition to prevent possible problems. Therefore, you should charge it prior to use.

NOTE: Batteries will not reach full charge the first time they are charged. Allow several cycles for them to fully charge.

CAUTION!

Make sure power supply is normal house voltage, 230 volts, 50Hz, AC only.

Charging Battery Pack With Charger JLH08215037G

1. While pressing the battery pack clip (7) gently slide out the battery pack (8) from driver drill.
2. Plug the battery charging adapter into a power outlet, and insert the output plug into the jack of charging connector (9).
The LED charging status lamp on the charger turns in GREEN to indicate the charger is ready.
3. Align the ribs on the charging connector with the grooves on the battery pack, and slide toward the battery clip. After the clicking sound, check that the push buttons have returned to their original position. The LED charging status lamp turns to RED to indicate it is charging.
4. Once the charging completed, the LED charging status lamp turns to GREEN. Remove the battery pack from the charging connector, and then plug off the charging adapter.

Charging Battery Pack With Charger XPP-2700 (Sold separately)

1. Plug the battery charger into the proper AC voltage source. A steady GREEN light will illuminate indicating the charger is connected to a proper power source.
2. Slide the ribs on the battery pack (8) into the slots on the battery charger until the latches on each side of battery pack snap in place and the battery pack is secured in the charger.
3. When the battery pack is secured in the charger, the charging status indicator LEDs on the charger will lit up in different combinations indicating charging status:
 - Stand by: GREEN light on
 - Charging: GREEN light on and RED light blink
 - Charging completed: GREEN and RED light on
 - Hot battery: RED and GREEN lights blink
 - Defective battery: RED light on only

HOW TO EXTEND THE LIFE OF THE BATTERY PACK

- Do not recharge the battery pack.
- When the battery pack is not going to be used for an extended period of time (six months or longer), store it with a battery being charged.
- Before storing the charger remove battery pack from the charger.

CAUTION: Do not overcharge the battery as this could damage the battery cells.

IMPORTANT INFORMATION FOR RECHARGING HOT BATTERIES

When using your tool continuously, the batteries in your battery pack will become hot. You should let a hot battery pack cool down for approximately 30 minutes before attempting to recharge.

OPERATING

NEVER COVER THE AIR VENTS SINCE THEY MUST ALWAYS BE OPEN FOR PROPER MOTOR COOLING.

DRILLING IN WOOD

To prevent splintering around the drilled hole on the reverse side of the work piece, place scrap lumber beneath the material to be drilled.

DRILLING IN METAL

Metals such as steel sheets, brass and aluminum sheets, stainless steel and pipe may also be drilled. Mark the point to be drilled with a nail or punch.

DRIVING SCREW

Match the bit and screw size to prevent damage to the screw head. For removing screws, push the reversing switch to the left position.

MAINTENANCE

After use, check the tool to make sure that it is in top condition. It is recommended that you take this tool to a RYOBI Authorized Service Center for a thorough cleaning and lubrication at least once a year.

DO NOT MAKE ANY ADJUSTMENTS WHILE THE MOTOR IS IN MOTION.

ALWAYS REMOVE THE BATTERY FROM THE TOOL BEFORE CHANGING REMOVABLE OR EXPENDABLE PARTS (BIT...ETC.), LUBRICATING OR WORKING ON THE UNIT.

WARNING!

To ensure safety and reliability, all repairs should be performed by an **AUTHORIZED SERVICE CENTER** or other **QUALIFIED SERVICE ORGANIZATION**.

SAVE THESE INSTRUCTIONS FOR FUTURE REFERENCE.

— NOTE —

RYOBI POWER EQUIPMENT WARRANTY

Subject to the warranty conditions below, this RYOBI tool (hereinafter called "the Product"), is warranted by Ryobi (herein called "the Company") to be free from defects in material or workmanship for a period of 24 months from the date of original purchase covering both parts and labour. Under the terms of this warranty, the repair or replacement of any part shall be the opinion of the Company or its authorised agent. Should service become necessary during the warranty period, the owner should contact the authorised Ryobi retailer from whom the product was purchased, or the nearest Company branch office. In order to obtain warranty service, the owner must include the Sales Docket and Warranty Certificate to confirm date of purchase. This Product is sold by the dealer or agent as principal and the dealer has no authority from the Company to give any additional warranty or guarantee on the Company's behalf except as herein contained or herein referred to.

Warranty Conditions

This warranty only applies provided that the Product has been used in accordance with the manufacturer's recommendations under normal use and reasonable care (in the opinion of the Company) and such warranty does not cover consumable components, damage, malfunction or failure resulting from

misuse, neglect, abuse, or used for a purpose for which it was not designed, or is not suited and no repairs, alterations or modifications have been attempted by other than an Authorised Service Agent. This guarantee will not apply if the tool is damaged by accident or if repairs arise from normal wear and tear.

Accessories such as bits, blades, sanding discs, cutting lines, etc., are excluded from this guarantee. Normal consumable parts, such as carbon brushes, bearings, chucks, cord assembly's, spark plugs, recoil pulleys and bump head assembly's are specifically excluded from this guarantee.

The Company accepts no additional liability pursuant to this warranty for the costs of traveling or transportation of the Product or parts to and from the service dealer or agent - which costs are not included in the warranty.

Nothing herein shall have the effect of excluding, restricting or modifying any conditions, warranty, right or liability imposed, to the extent only that such exclusion, restriction or modification would render any term herein void.



STEVENS & CO (Pty) Ltd
604, 16th Street, Randjespark
Midrand, South Africa

P O Box 4059
HALFWAY HOUSE
1685, South Africa

Tel: +27 (11) 357-9600
Fax: +27 (11) 805-5541
email: stevens@ryobi.co.za

THIS WARRANTY FORM SHOULD BE RETAINED BY THE CUSTOMER AT ALL TIMES.

For your record and to assist in establishing date of purchase (necessary for in-warranty service), please keep your purchase docket and this form, completed with the following particulars.

PURCHASED FROM:.....

ADDRESS OF DEALER:.....

DATE:..... MODEL NO..... SERIAL NO.....

Present this form with your Purchase Docket when Warranty Service is required.