

RYOBI®

OWNER'S OPERATING MANUAL BELT DRIVEN COMPRESSOR MODEL RC-3100B

SPECIFICATIONS

Voltage.....	230V~50Hz
Rated power.....	2.2kW/3.0HP
Intermittent duty.....	S3 75%
Receiver capacity.....	100l
Type.....	Oil lubricated
Free air delivery (FAD).....	365l/min
CFM.....	12.9
Oil type.....	SAE-30
Oil capacity.....	500ml
Working pressure.....	10bar/145psi
No load speed.....	1375min ⁻¹
Sound pressure level.....	L _{pA} 71.5dB(A),k=3dB(A)
Sound power level.....	L _{WA} 91.5dB(A),k=3dB(A)
Net weight.....	59.2kg

THANK YOU FOR BUYING A RYOBI BELT DRIVEN COMPRESSOR

Your new compressor has been engineered and manufactured to Ryobi's high standard of dependability, ease of operation and operator safety. Properly cared for, it will give you years of rugged, trouble free performance. If you use your compressor properly and only for what it is intended, you will enjoy years of safe, reliable service.



CAUTION: Carefully read through this entire owner's manual, paying close attention to the general safety rules and rules for safe operation, before using.

KEEP THIS MANUAL FOR FUTURE REFERENCE

IMPORTANT SAFETY INSTRUCTIONS

The purpose of safety rules is to attract your attention to possible dangers. The safety symbols and the explanations with them, require your careful attention and understanding. The safety warnings do not by themselves eliminate any danger. The instruction or warnings they give are not substitutes for proper accident prevention measures.



SAFETY ALERT SYMBOL. Indicates caution or warning. May be used in conjunction with other symbols or pictures.

Failure to obey a safety warning can result in serious injury to yourself or to others. Always follow the safety precautions to reduce the risk of fire, electric shock and personal injury.

Do not attempt to operate this tool until you have read thoroughly and completely understood the safety rules, etc. contained in this manual. Failure to comply can result in accidents involving fire, electric shock or serious personal injury. Save this Owners Operating Manual and review it frequently for continual safe operation and for instructing others who may use this tool.

APPLICATIONS

Air compressors are utilized in a variety of air system applications. Match hoses, connectors, air tools, and accessories to the capabilities of the air compressor.

SPECIFIC SAFETY INSTRUCTIONS



WARNING. If not used and maintained correctly this compressor when used with some pneumatic tools can cause serious injury and death. Before attempting to operate this machine, it is important that you read, understand and follow these instructions very carefully. They are designed for the safety of yourself and others ensuring a long and trouble free service life from your machine. If not used correctly and as detailed in these instructions pneumatic tools can be dangerous. This product can cause injury to the operator and others.

The warnings and safety instructions must be followed to ensure reasonable safety and efficiency in using this product.

NOTE: The operator is responsible for following the warnings and safety instructions in this manual and on the product.

Ensure that this compressor is disconnected from the mains supply when not in use and the air receiver fully discharged before servicing, lubricating or making adjustments and when changing accessories. Always switch ON and OFF using the ON/OFF switch on the compressor before switching OFF at the mains supply.



WARNING. When spraying paint or cleaning agents the fine mist produced could ignite. When performing this type of operation the compressor must be a minimum of 4 Metres away from the work area. Do not smoke and keep naked flames and other sources of ignition well away from the work area. Make sure that the area in which you are working has good ventilation and protect your nose and mouth with a suitable face mask. Always check the safety data sheets for substances being sprayed & ensure manufacturers instructions are followed.

Protect yourself. Goggles will protect your eyes from flying particles.

These compressors produce noise levels in excess of 70dB(A). Persons working near the compressor must be supplied with ear protection.

Drain tanks of moisture after each day's use. If unit will not be used for a while, it is best to leave drain valve open until such time as it is to be used. This will allow moisture to completely drain out and help prevent corrosion on the inside of tanks.

This air compressor must be used in a suitable environment. There must be adequate ventilation, the ambient temperature must be +5/+40°C. The working area must be free from dust, acid vapour, explosive gasses and flammable materials.

Compressed air can be potentially dangerous when not used correctly. Do not exceed the maximum rated air pressure for the accessory. Do not direct compressed air at yourself, any other person or animals. Do not direct any liquid or any other material that is being sprayed by yourself towards any other person or animals.

Only use hoses and connectors designed for use with compressed air. The maximum working pressure of hoses and connectors must be higher than the maximum working pressure of the compressor. Do not attempt to move the compressor by pulling on the air hose.

IMPORTANT SAFETY INSTRUCTIONS

This compressor is designed for tyre inflation, the operation of pneumatic tools, spray painting and spraying non-corrosive cleaning agents. Do not use this compressor for filling cylinders for breathing or diving apparatus. Compressed air from this compressor must not be used for pharmaceutical, food or health applications.

When spraying flammable liquids such as paint and non-corrosive cleaning agents the distance between the compressor and the work area must be a minimum of 4 metres. When spraying liquids always wear a suitable face mask designed for protection against the liquid being sprayed. Always wear approved safety glasses.

Do not attempt to modify the compressor or any pneumatic tools in any way. Use only accessories and pneumatic tools that are rated for the capacity of the compressor. Never leave the compressor pressurised.

Always transport the compressor by lifting or pulling it with the appropriate grips or handles.

Do not insert your fingers or other objects inside the motor housing to avoid physical damage or damage to the compressor.

If any part of the compressor is damaged, it should be carefully checked to determine that it will operate correctly and perform its intended function. Check for the alignment of parts, damage to parts, air leaks and any other conditions that may affect its operation. A guard or any other part that is damaged or defective should be properly repaired or replaced by an authorised service centre. Defective pressure switches must be replaced prior to further use of the compressor.



WARNING. This compressor must be connected to a power socket that is safeguarded by a suitable circuit breaker or fuse.

To reduce the risk of electric shock, do not expose to rain. Store indoors.

Inspect tanks yearly for rust, pin holes, or other imperfections that could cause it to become unsafe. Never weld or drill holes in the air tanks.

Only use recommended parts. To avoid the risk of bursting, only hoses with a rated pressure of 10 bar, or more should be used. Never attempt to repair faulty hoses.

Avoid kinking or trapping the air hose. Always replace faulty hoses - never attempt a repair if a leak is detected.

Make sure the hose is free of obstructions or snags. Entangled or snarled hoses can cause loss of balance or footing and may become damaged.

Do not operate this air compressor if it does not contain a legible warning label.

Always disconnect the air supply and power supply before making adjustments, servicing a product, or when a product is not in use.

Make sure your extension cord is in good condition. When using an extension cord, be sure to use one heavy enough to carry the current your product will draw. A wire gauge size (A.W.G.) of at least 14 is recommended for an extension cord 25 feet (7.6m) or less in length. A cord exceeding 50 feet (15.2m) is not recommended. If in doubt, use the next heavier gauge. The smaller the gauge number, the heavier the cord. An undersized cord will cause a drop in line voltage resulting in loss of power and overheating.

Never store a tool with air connected. Storing the tool with air connected can result in unexpected firing and possible serious personal injury.

Protect your lungs. Wear a face or dust mask if the operation is dusty. Following this rule will reduce the risk of serious personal injury.

Keep the motor vent clear and free from dust, wipe regularly to maintain an adequate supply of clean air to the air compressor.

If the power supply cord is damaged, it must be replaced only by the manufacturer or by an authorized service center to avoid risk.

SAVE THESE INSTRUCTIONS

1) WORK AREA

- a) **Keep your work area clean and well lit.** Cluttered benches and dark areas invite accidents. Floor must not be slippery from wax or dust.
- b) **Do not operate air compressors in explosive atmospheres, such as in the presence of flammable liquids, gases, or dust.** Power tools create sparks which may ignite the dust or fumes.

IMPORTANT SAFETY INSTRUCTIONS

c) **Keep bystanders, children, and visitors away while operating an air compressor.** Distractions can cause you to lose control.

d) **Operate air compressor in an open area at least 50cm away from any wall or object that could restrict the flow of fresh air to ventilation openings.**

2) ELECTRICAL SAFETY

a) **Avoid body contact with grounded surfaces such as pipes, radiators, ranges, and refrigerators.** There is an increased risk of electric shock if your body is grounded.

b) **Don't expose air compressors to rain or wet conditions.** Water entering an air compressor will increase the risk of electric shock.

c) **Do not abuse the cord. Never use the cord to carry the air compressor or pull the plug from an outlet. Keep cord away from heat, oil, sharp edges, or moving parts. Replace damaged cords immediately.** Damaged cords increase the risk of electric shock.

d) **When operating an air compressor outside, use an outdoor extension cord marked "W-A" or "W".** These cords are rated for outdoor use and reduce the risk of electric shock.

3) PERSONAL SAFETY

a) **Eye protection which conforms to ANSI specifications and provides protection against flying particles both from the FRONT and SIDE should ALWAYS be worn by the operator and others in the work area when loading, operating, or servicing this product.** Eye protection is required to guard against flying fasteners and debris, which could cause severe eye injury.

b) **The employer and/or user must ensure that proper eye protection is worn.** We recommend a Wide Vision Safety Mask for use over eyeglasses or standard safety glasses that provide protection against flying particles both from the front and side. Always use eye protection which is marked to comply with ANSI Z87.1.

c) **Additional safety protection will be required in some environments.** For example, the working area may include exposure to a noise

level which can lead to hearing damage. The employer and user must ensure that any necessary hearing protection is provided and used by the operator and others in the work area. Some environments will require the use of head protection equipment. When required, the employer and user must ensure that head protection marked to comply with ANSI Z89.1 is used.

d) **Stay alert, watch what you are doing, and use common sense when operating the air compressor. Do not use product while tired or under the influence of drugs, alcohol, or medication.** A moment of inattention while operating an air compressor may result in serious personal injury.

e) **Dress properly. Do not wear loose clothing or jewellery. Contain long hair. Keep your hair, clothing, and gloves away from moving parts.** Loose clothes, jewellery, or long hair can be caught in moving parts.

f) **Do not overreach. Keep proper footing and balance at all times.** Proper footing and balance enables better control of the product in unexpected situations.

g) **Use safety equipment. Always wear eye protection.** Dust mask, nonskid safety shoes, hard hat, or hearing protection must be used for appropriate conditions.

h) **Do not use on a ladder or unstable support.** Stable footing on a solid surface enables better control of the air compressor in unexpected situations.

4) AIR COMPRESSOR USE AND CARE

a) **Do not exceed the pressure rating of any component in the system.**

b) **Protect material lines and air lines from damage or puncture.** Keep hose and power cord away from sharp objects, chemical spills, oil, solvents, and wet floors.

c) **Check hoses for weak or worn condition before each use, making certain all connections are secure.** Do not use if defect is found. Purchase a new hose or notify an authorized service center for examination or repair.

SPECIFIC SAFETY RULES

- d) **Release all pressures within the system slowly.** Dust and debris may be harmful.
 - e) **Store idle air compressors out of the reach of children and other untrained persons.** Air compressors are dangerous in the hands of untrained users.
 - f) **Maintain air compressors with care.** Follow maintenance instructions. Properly maintained products are easier to control.
 - g) **Check for misalignment or binding of moving parts, breakage of parts, and any other condition that may affect the product's operation. If damaged, have the air compressor serviced before using.** Many accidents are caused by poorly maintained products.
 - h) **Keep the exterior of the air compressor dry, clean, and free from oil and grease.** Always use a clean cloth when cleaning. Never use brake fluids, gasoline, petroleum-based products, or any strong solvents to clean the unit. Following this rule will reduce the risk of deterioration of the enclosure plastic.
- 5) **SERVICE**
 - a) **When servicing a product, use only identical replacement parts. Follow instructions in the Maintenance section of this manual.** Use of unauthorized parts or failure to follow Maintenance instructions may create a risk of injury.
 - b) **Service must be performed only by qualified repair personnel.** Service or maintenance performed by unqualified personnel may result in a risk of injury.
 - c) **Disconnect power supply, open drain valve to decompress tanks and allow water to drain, and allow air compressor to become cool to the touch before servicing.** Turn pressure regulator knob fully counterclockwise after shutting off air compressor.

WARNING! FILL WITH COMPRESSOR OIL BEFORE USING. RUNNING THE COMPRESSOR WITH NO OIL OR LOW OIL VOIDS WARRANTY

ELECTRICAL

ELECTRICAL CONNECTION

This product is powered by a precision-built electric motor. It should be connected to a power supply that is 230 V, AC only (normal household current), 50 Hz. Do not operate this product on direct current (DC). A substantial voltage drop will cause a loss of power and the motor will overheat. If the product does not operate when plugged into an outlet, double check the power supply.

GROUNDING INSTRUCTIONS

This product must be grounded. In the event of a malfunction or breakdown, grounding provides a path of least resistance for electric current to reduce the risk of electric shock. This product is equipped with an electric cord having an equipment-grounding conductor and a grounding plug. The plug must be plugged into a matching outlet that is properly installed and grounded in accordance with all local codes and ordinances.

Do not modify the plug provided. If it will not fit the outlet, have the proper outlet installed by a qualified electrician.



WARNING. Improper installation of the grounding plug is liable to result in a risk of electric shock. When repair or replacement of the cord is required, do not connect the grounding wire to either flat blade terminal. The wire with insulation having an outer surface that is green with or without yellow stripes is the grounding wire.

Check with a qualified electrician or service personnel if the grounding instructions are not completely understood, or if in doubt as to whether the product is properly grounded.

Repair or replace a damaged or worn cord immediately.

This product is for use on a nominal 230 V circuit and has a grounding plug. Only connect the product to an outlet having the same configuration as the plug. Do not use an adaptor with this product.

DESCRIPTION

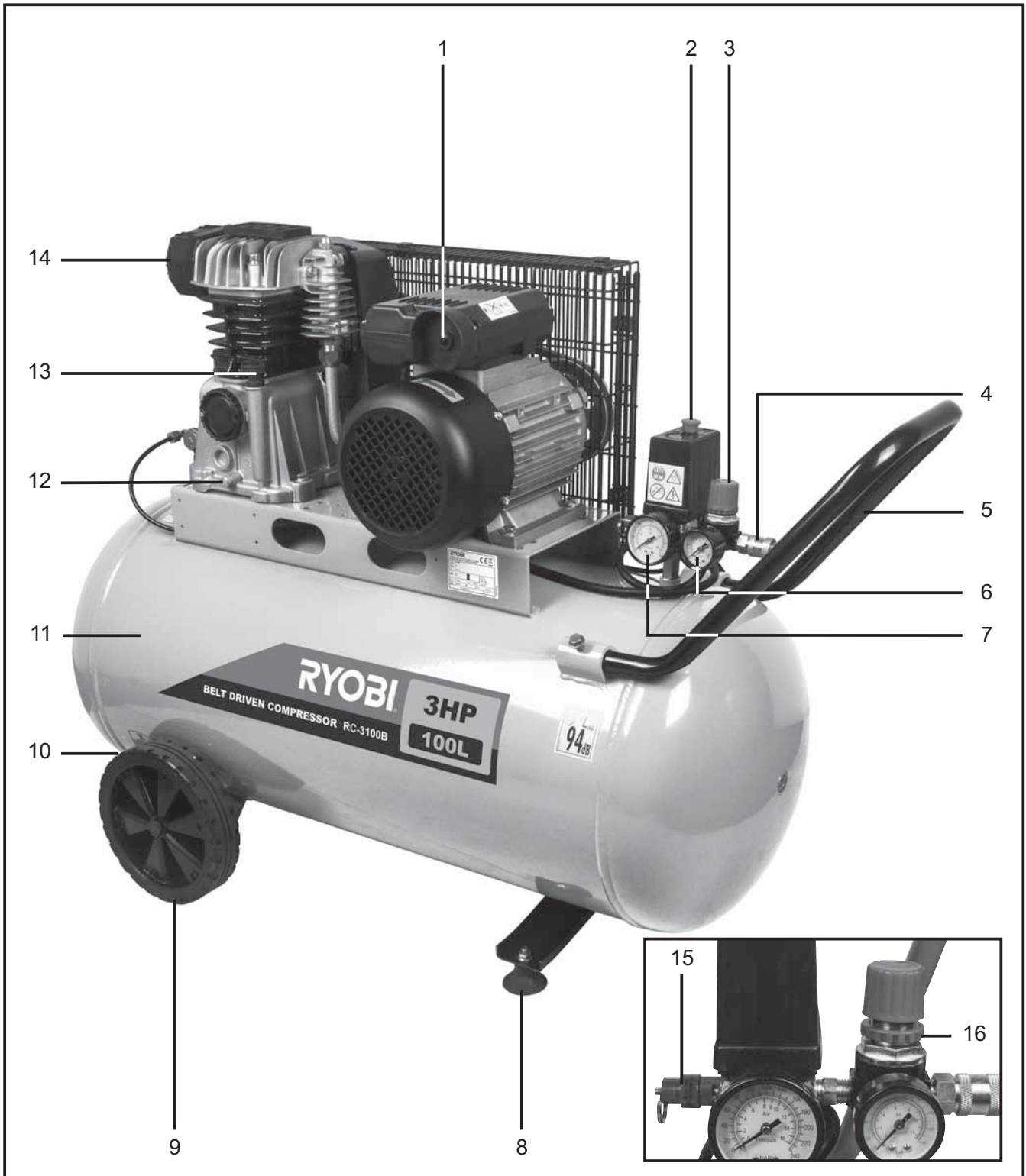

- | | |
|---|---|
| 1. Reset button | 9. Wheel x 2 |
| 2. On/Off pressure switch | 10. Drain valve |
| 3. Air outlet pressure regulator | 11. Air receiver tank |
| 4. Air outlet quick release connector (regulated) | 12. Oil drain plug |
| 5. Transportation handle | 13. Dipstick |
| 6. Air outlet pressure gauge | 14. Air filter |
| 7. Air receiver pressure gauge | 15. Safety valve |
| 8. Rubber foot x 2 | 16. Air outlet pressure regulator lock ring |

UNPACKING



CAUTION. This packaging contains sharp objects. Take care when unpacking. Remove the machine, together with the accessories supplied, from the packaging. Check carefully to ensure that the machine is in good condition and account for all the accessories listed in this manual. Also make sure that all the accessories are complete.

If any parts are found to be missing, the machine and its accessories should be returned together in their original packaging to the retailer. Do not throw

the packaging away, keep it safe throughout the guarantee period, then recycle if possible, otherwise dispose of it by the proper means. Do not let children play with empty plastic bags due to the risk of suffocation. Take care when lifting the compressor from the packaging.



CAUTION. Do not lift the compressor by the pressure regulator. To prevent injury, get assistance when lifting or moving the compressor. This unit weighs 59.2kg.

ASSEMBLY

PACKING CONTENTS

- Belt driven compressor
- Wheels x 2
- Wheel fixings (bolt, nut) x 2
- Rubber foot x 2
- Rubber foot fixings (bolt, nut) x 2
- Dipstick
- Operator's Manual



WARNING. If any parts are damaged or missing, do not operate this product until the parts are replaced. Use of this product with damaged or missing parts could result in serious personal injury.



WARNING. Do not connect to power supply until assembly is complete. Failure to comply could result in accidental starting and possible serious personal injury.



WARNING. Do not attempt to modify this product or create accessories not recommended for use with this product. Any such alteration or modification is misuse and could result in a hazardous condition leading to possible serious personal injury.

FITTING THE WHEELS

Fit the two transportation wheels to either side of the compressor as shown in Fig.1 using a spanner (not supplied).

FITTING THE RUBBER FOOT

To fit a rubber foot locate the bolt provided through the hole in the rubber foot and hole on the compressor support bracket (Fig.2). Tighten the nut with a spanner or socket (not provided) to secure the rubber foot into position.

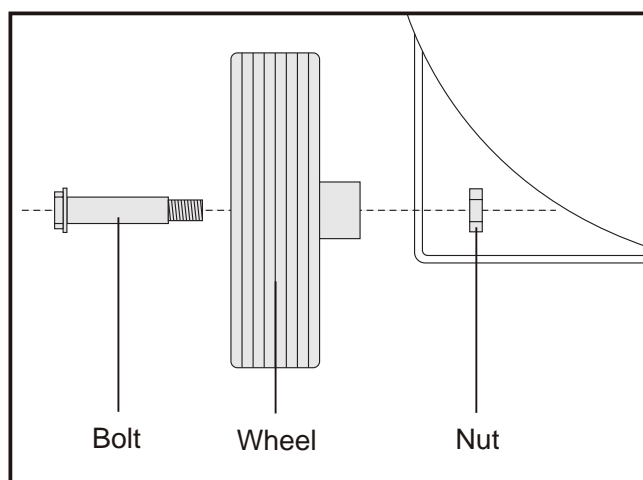

Fig. 1

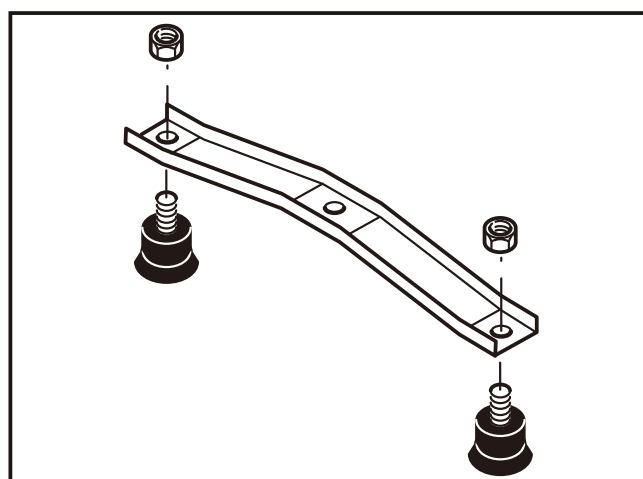

Fig. 2

ASSEMBLY

INSTALLING THE DIPSTICK

Remove the plastic shipping plug from the oil fill hole. Remove the dipstick from the poly bag and push it into the oil fill hole (Fig 3).



WARNING. You must replace the plastic shipping plug with the dipstick. Failure to do so may result in injury.

FILLING THE COMPRESSOR WITH OIL



WARNING. Do not attempt to start the air compressor without first adding oil to the crankcase. Serious damage can result unless filled with oil. The pump is shipped without oil from the factory. Only use non-detergent oils since multi-viscosity motor oils leave carbon deposits on pump components, thus reducing performance and compressor life.



WARNING. Drain the tank to release all tank air pressure before removing the dipstick. Be sure the air vent in dipstick (Fig.3) is free from debris. If air vent is blocked, pressure can build in crankcase causing damage to the compressor and possible personal injury.

Remove the dipstick by twisting it upwards by hand. Fill the compressor pump with an air compressor oil such as SAE-30 non-detergent (API CG/CD Heavy Duty) oil at slow intervals, Fig.4, until the oil reaches between the minimum and maximum marks on the dipstick (Fig.3). Take care not to exceed the maximum mark. Use SAE-10 during extreme winter conditions.

LOCATING THE AIR COMPRESSOR

This compressor should be positioned on a stable, flat surface (or one with a maximum inclination of 15°), Fig.5. Ensure that it is completely stable.

Do not cover or box in the compressor. Always position it with good all round ventilation.

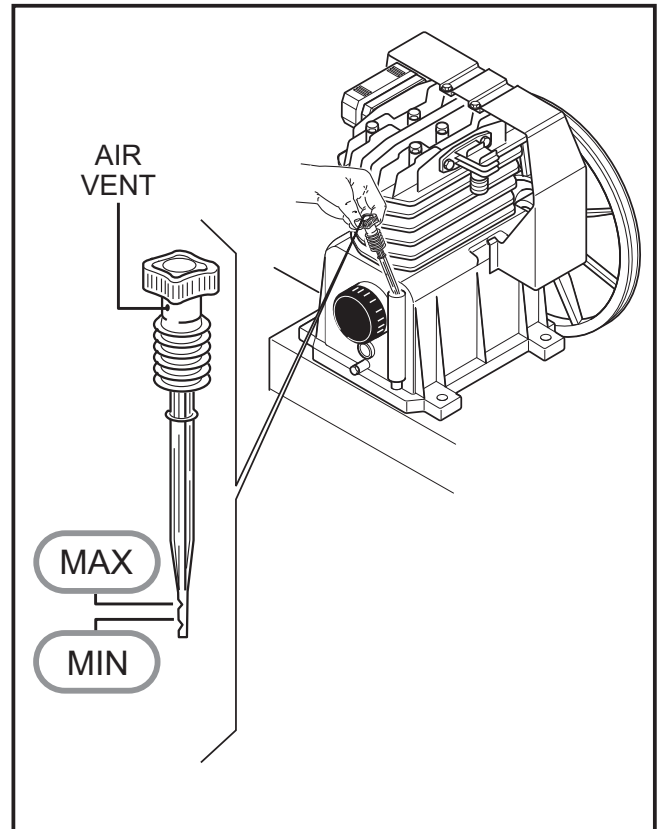

Fig. 3

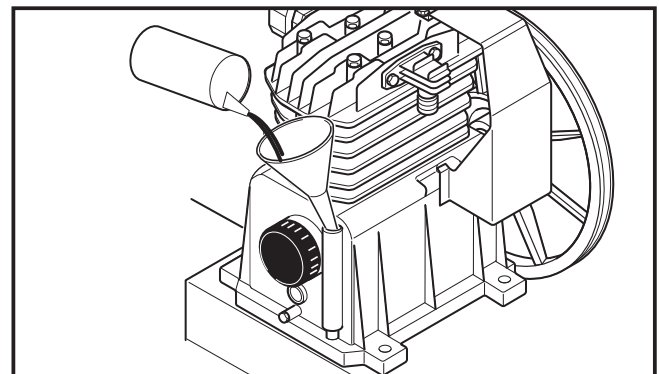

Fig. 4

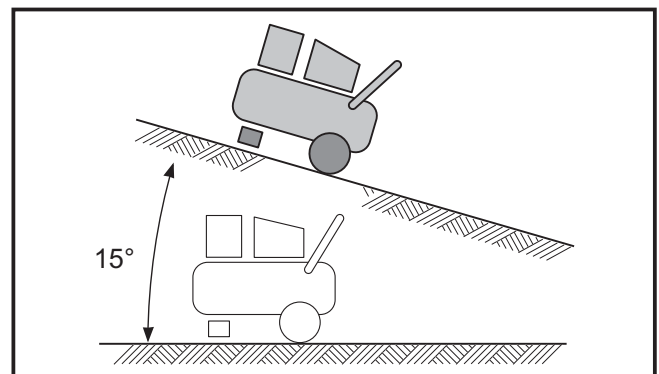

Fig. 5

ASSEMBLY

MOVING THE AIR COMPRESSOR

Before moving the compressor, switch off and disconnect it from the mains power supply.

- Always use the handle
- Do not lift by (or put strain on) air taps, valves or hoses.
- Take care when moving the compressor to avoid damaging the valves or fittings.



WARNING. When the compressor is used for spraying paint or spraying cleaning agents the fine mist produced could ignite. When performing this type of operation the compressor must be a minimum of 4 Metres away from the work area. Do not smoke and keep naked flames and other sources of ignition well away from the work area.

OPERATION



DANGER. Do not disassemble any part of the compressor with air in tank - bleed the tank. Failure to depressurize tank could result in explosion and/or serious personal injury.



WARNING. Do not allow familiarity with products to make you careless. Remember that a careless fraction of a second is sufficient to inflict severe injury.



WARNING. Always wear eye protection with side shields marked to comply with ANSI Z87.1. Failure to do so could result in objects being thrown into your eyes resulting in possible serious injury.



WARNING. Do not use any attachments or accessories not recommended by the manufacturer of this product. The use of attachments or accessories not recommended can result in serious personal injury.



WARNING. Do not attach any tools to the open end of the hose until start-up has been completed.

NOTE. Do not use in an environment that is dusty or otherwise contaminated. Using the air compressor in this type of environment may cause damage to the unit.

NOTE. The wiring to a receptacle and the length of any extension cords being used play an important role in the operation of this product. Wiring intended for lights cannot properly carry an air compressor motor, and wire that is heavy enough for a short distance may be insufficient for a greater distance.

Before using this product, verify your receptacle is wired appropriately for air compressor use and the length and gauge of any extension cord used is sufficient to carry the current of the air compressor.

BASIC COMPRESSOR OPERATION

Important Note: This manual is provided to allow the correct assembly and basic safe operation of the compressor. It must be read in conjunction with the manual that is supplied with any other accessory intended for use with this compressor. For more detailed information on the use of compressors and accessories, we strongly recommend that you purchase a good quality publication, in order to allow you to use this product to its full potential.

The electric motor drives an air pump which draws in air from the atmosphere and delivers it into the air receiver tank through the air receiver tank supply tube. When the air pressure in the air receiver tank reaches the operating pressure of 10 Bar the pressure switch operates and switches OFF the mains supply to the motor. At the same time the air that is in the pump cylinder, air receiver tank, supply tube and the pressure switch is discharged. This depressurises the pump and the pressure regulating system allowing the pump to re-start when the air pressure in the air receiver tank falls below the minimum operating pressure of 8 Bar. The pressure switch is fitted with a delayed discharge valve which will start the air pump motor. The pressure relief safety valve is set to operate at 10.5 Bar and is connected directly onto the air receiver tank and will operate if the set pressure of 10.5 Bar is exceeded should the pressure switch fail.

OPERATION

OVERLOAD PROTECTION

This compressor has a thermal overload device. If the motor gets too hot, the thermal overload device cuts the power which prevents damage to the motor.

If the thermal overload device operates, let the motor cool down for 5 minutes and push the reset button.

If you start the compressor and the overload cutout operates again, stop the compressor and disconnect from the power supply and have your compressor examined by a qualified service agent.

SWITCHING ON AND OFF



WARNING. Switching On & Off must be done using the On/Off switch mounted on the compressor. Switching the compressor Off at the mains supply can damage the motor and will invalidate the guarantee.

Before switching on the power supply to the compressor check that the On/Off switch is in the Off position (pressed in) (Fig.6).

Check that the air outlet pressure regulator is closed (Fig 7).

Check that the drain valve is closed (Fig.8).

Connect the compressor to a suitable 16A mains supply. Switch on the compressor by pulling up the On/Off switch (Fig.9). The compressor will now start.

When the air receiver tank is pressurised to its working capacity the compressor will automatically switch off. When the compressor switches off there will be the sound of leaking air while the pressure regulating system is depressurised, this will last for only a few seconds and is quite normal. Check all valves and regulators for leaks. Note during extended periods of use the air receiver tank supply tube will become hot.



WARNING. Always ensure the switch is in the OFF position (pressed in) and the pressure gauge reads zero before changing air tools or disconnecting the hose from the air outlet. Failure to do so could result in possible serious personal injury.

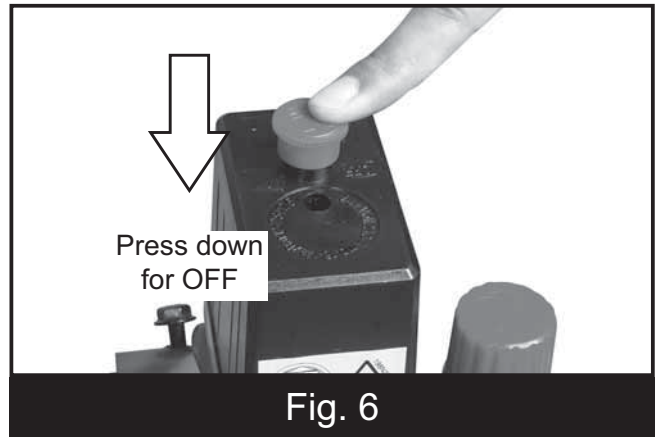

Fig. 6

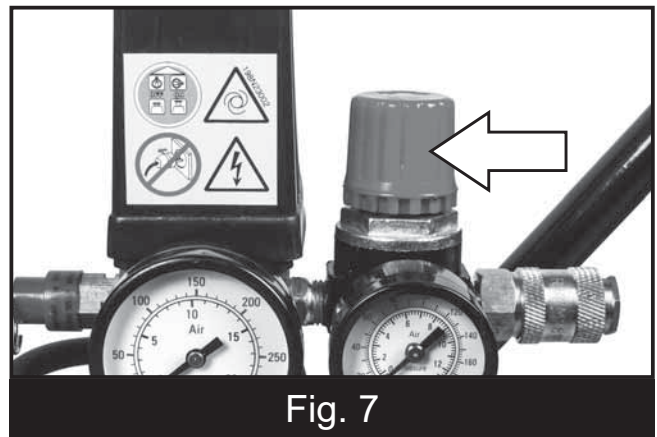

Fig. 7

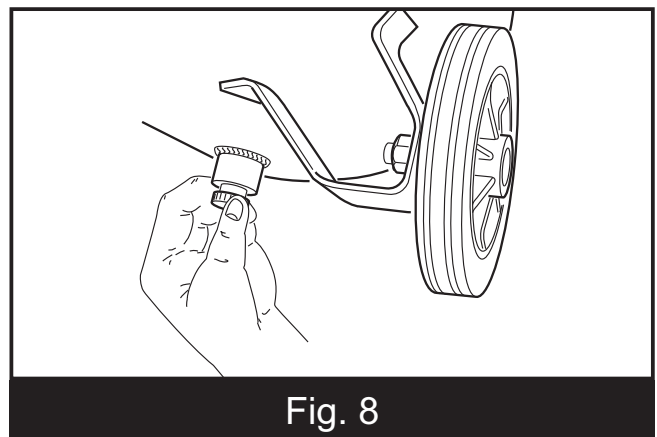

Fig. 8

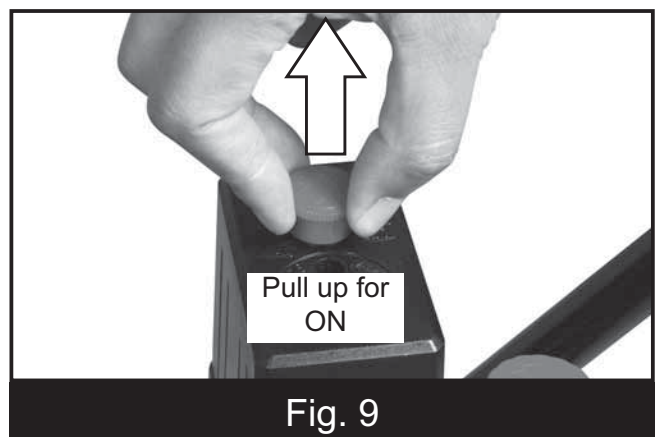

Fig. 9

OPERATION

CONNECTING/DISCONNECTING AIR HOSE



WARNING. Never exceed the air tool's pressure rating as recommended by the manufacturer. When using this air compressor as an inflation device, always follow the maximum inflation guidelines stated by the manufacturer of the item being inflated.

Make sure the air compressor is off and unplugged.

Rotate pressure regulator knob fully in the counter-clockwise direction so that the outlet pressure is at zero (0) psi.

Connect a hose to the compressor using the hose to compressor quick release connector (Fig.10). Make sure to push the air fitting fully into the coupler until the sleeve springs forward to lock in place.

When using the regulated air output first determine the working pressure of the accessory by referring to the accessory manual. Slowly open the air outlet pressure regulator (Fig.11) at the same time observing the air outlet pressure gauge until the pressure gauge reads the minimum pressure for the accessory.

Fine adjustments to the air pressure can be made until the accessory is working at its optimum performance.

When the correct operating air pressure has been set, the air outlet pressure regulator can be locked by tightening the locking ring (Fig.12).

Do not exceed the maximum rated air pressure for the accessory.

NOTE: Always use the minimum amount of pressure necessary for your application. Using a higher pressure than needed will drain air from the tank more rapidly and cause the unit to cycle on more frequently.

To disconnect an air hose or an air tool:

Confirm that the outlet pressure is at zero (0) psi.

When disconnecting a hose from the quick release connector, always firmly hold the fitting end of the hose.

Push back on the release sleeve on the quick release connector. With a firm grip, pull out the quick-connect air fitting that is attached to the quick release connector, Fig.13.

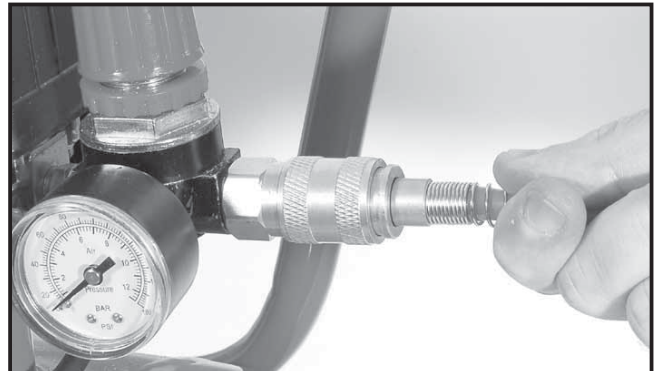

Fig. 10

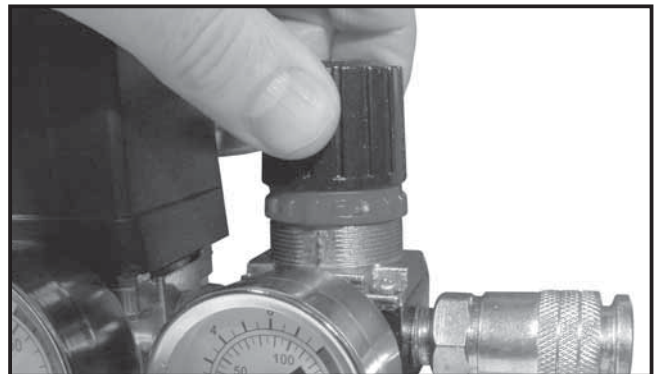

Fig. 11

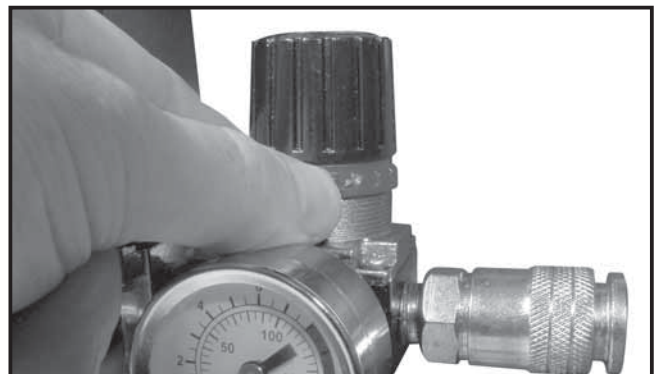

Fig. 12

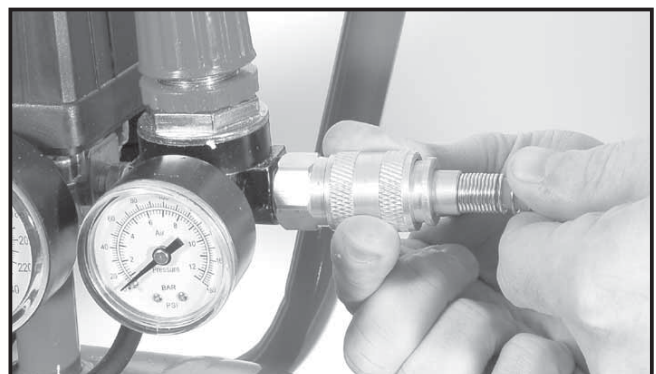

Fig. 13

OPERATION

SAFETY VALVE

Check the operation of the safety valve, under pressure, daily by pulling the ring as shown in Fig.14. Air should be released when you pull the ring and stop when the ring is released.

- If the valve does not operate as described, or if the valve is stuck, it must be replaced by qualified service personnel before using the compressor.



WARNING. Do not remove or attempt to adjust the safety valve.



DANGER. Do not attempt to tamper with the safety valve. Anything loosened from this device could fly up and hit you. Failure to heed this warning could result in death or serious personal injury.

DRAINING THE RESERVOIR



CAUTION. It is important to drain the reservoir before storage to help prevent tank corrosion.

Switch the air compressor off, by pressing the On/Off button to the off position (pressed down), and remove the plug from the mains supply.

Pull the ring on the safety valve to release pressure until pressure gauge reads less than 20 psi.

Release the ring.

Place a suitable container beneath the compressor to catch any condensation.

Carefully undo the drain valve nut anti-clockwise until you hear a hissing noise, this is the reservoir depressurising (Fig.15).

When the gauge indicates zero and the hissing has stopped, tighten the drain valve nut again.

OIL CHANGING

Replace the oil after the first 100 hours of operation and every 300 hours subsequently. Remember to check the oil level at regular intervals.

For changing the pump oil, be sure to do the following:

1. Turn the unit off and unplug the power cord from the receptacle.

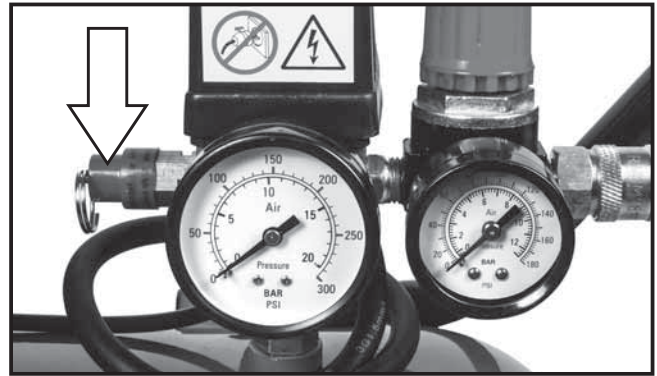

Fig. 14

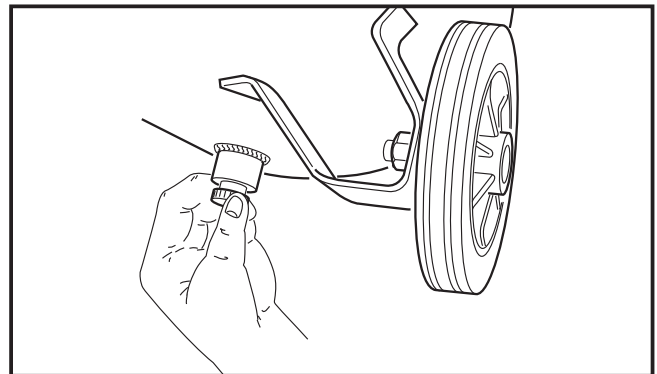

Fig. 15

2. Allow the compressor time to cool if it has been in operation.
3. Open the drain valve to bleed all air from the tank.
4. Close the drain valve.
5. Remove the dipstick on the pump.
6. Remove the oil drain plug with a box end wrench or socket. Drain the oil into a suitable container and dispose of properly. The compressor may need to be tipped slightly towards the drain hole to allow all of the oil to drain.
7. Reattach the oil drain plug.
8. Refill the compressor pump with an air compressor oil such as SAE-30 non-detergent (API CG/CD Heavy Duty) oil at slow intervals until the oil reaches between the minimum and maximum marks on the dipstick. Take care not to exceed the maximum mark. Use SAE-10 during extreme winter conditions.

MAINTENANCE



WARNING. When servicing use only identical replacement parts. Use of any other parts may create a hazard or cause product damage.



WARNING. Always wear eye protection with side shields marked to comply with ANSI Z87.1. Failure to do so could result in objects being thrown into your eyes resulting in possible serious injury.



WARNING. Before carrying out any maintenance, always disconnect the compressor from the mains supply, drain the air receiver and, if necessary, allow the machine to cool down before starting work.

CLEAN THE AIR FILTER (MONTHLY)

The air filter must be examined monthly, more often in dusty conditions.

Remove the securing bolt and pull the filter from the compressor, Fig.16.

Unclip the front and rear of the filter and pull out the filter element, Fig.17.

Clean the filter using a soft brush.

If necessary, the filter can be carefully cleaned in warm soapy water.

Rinse and let the filter dry completely before refitting.

If the filter or filter element is damaged, you must replace it.

Reassemble the filter and refit it to the compressor using the securing bolt.

CHECK THE NON-RETURN VALVE (EVERY 6 MONTHS)

If the reservoir pressure decreases for no apparent reason, it is possible that the non-return valve is leaking. To check this:

Make sure that the reservoir is not under pressure and the compressor is switched OFF.

Examine the non-return valve, and replace the gasket and valve if necessary, Fig.18.

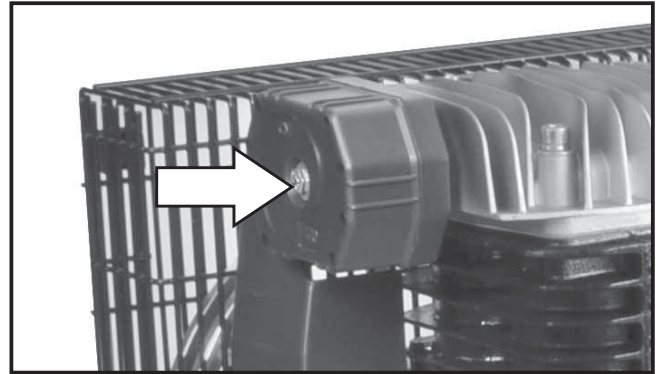

Fig. 16

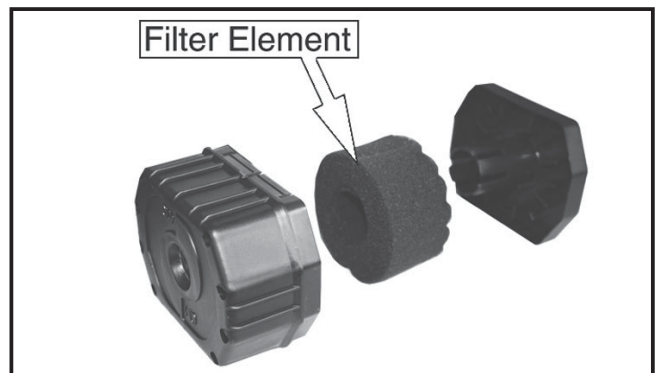

Fig. 17

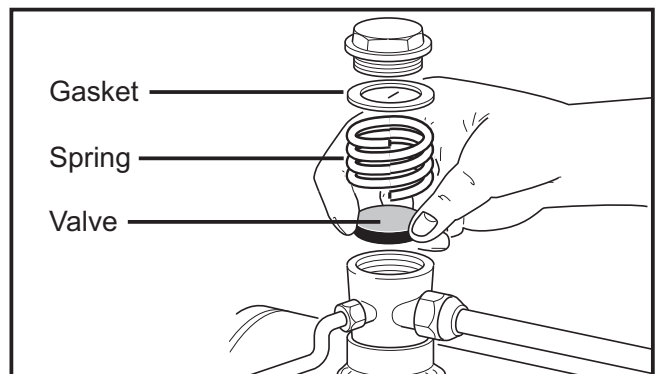

Fig. 18

MAINTENANCE

CHECKING THE BELT TENSION



WARNING. Make sure that the compressor is disconnected from the electrical supply before checking the drive belt.

The belt must flex by approximately 10 mm when a 3 Kg load is applied (Fig.19). Reset the tension if necessary, ensuring that the pulley and flywheel remain correctly aligned.

GENERAL MAINTENANCE

The compressor must be drained completely by opening the drain valve. Drain the air receiver tank after approx. 2 hours of use.

The air filter can be removed for either cleaning or replacing. Clean the air filter element after every 100 hours of use or if low pressure is experienced. Replace the air filter after 200 hours of use. Note: Under no circumstances should the compressor be operated with the air filter removed.

Cleaning and maintaining the compressor regularly will give a long and trouble free life.

Before long term storage it is advisable to give the compressor a thorough clean. This should include the removal of all fitted accessories. Do not use any solvents as these can damage plastic parts.

Only use a clean cloth dampened with warm soapy water. Any metal parts should be given a wipe with a light machine oil to prevent rusting.

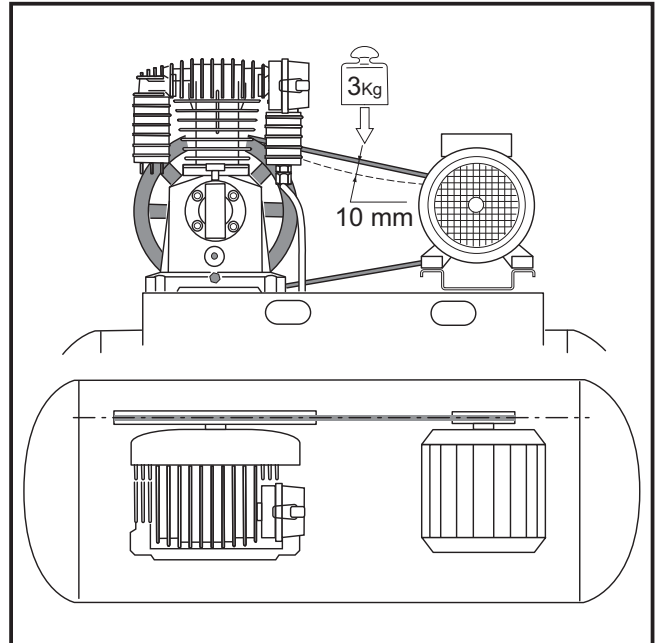

Fig. 19



WARNING. Do not at any time let brake fluids, gasoline, petroleum-based products, penetrating oils, etc., come in contact with plastic parts. Chemicals can damage, weaken or destroy plastic which may result in serious personal injury.

STORAGE

When you have finished using the air compressor:

- Set the switch to "OFF" and unplug the cord.
- Be sure to drain the moisture from the air tank.
- Protect the electrical cord and air hose from damage.
- Store the air compressor in a clean and dry location away from children.



SERVICE

Now that you have purchased your tool, should a need ever exist of repair or service, simply contact your nearest Ryobi Authorised Service Centre or other qualified service organisation. Be sure to provide all pertinent facts when you call or visit.

TROUBLESHOOTING













PROBLEM	POSSIBLE CAUSE	REMEDY
The compressor has stopped and does not start.	Bad electrical connections. Overload cutout switch has tripped. Motor windings burnt out.	Check electrical connections. Clean and tighten if necessary. Switch off and wait approx 5 minutes. Press the reset button and switch on again. Contact your nearest service agent.
The compressor does not reach the set pressure and overheats easily.	Compressor head gasket blown or valve broken.	Return the machine to your nearest service agent.
Compressor does not start.	The reservoir has already fully pressurised.	Open drain valve to expel air. Compressor should start again when pressure reduces.
Air leaking from the non-return valve when the compressor is not running.	Faulty non-return valve.	Drain receiver completely of air. Remove the valve end plug, Carefully clean the valve seat and the gasket. Reassemble.
Air pressure from the regulator will not adjust.	The diaphragm within the regulator body is broken.	Replace regulator.
The compressor is very noisy and makes a metallic knocking sound.	Compressor damaged and needs overhaul.	Return the machine to your nearest service agent.

SYMBOLS

SYMBOL	SIGNAL	MEANING
	DANGER:	Indicates an imminently hazardous situation, which, if not avoided, will result in death or serious injury.
	WARNING	Indicates a potentially hazardous situation, which, if not avoided, could result in death or serious injury.
	CAUTION	Indicates a potentially hazardous situation, which, if not avoided, may result in minor or moderate injury.
	CAUTION	(Without Safety Alert Symbol) Indicates a situation that may result in property damage.

SYMBOLS

Some of the following symbols may be used on this product. Please study them and learn their meaning. Proper interpretation of these symbols will allow you to operate the product better and safer.

SYMBOL	NAME	DESIGNATION/EXPLANATION
	Safety Alert Symbol	Indicates danger, warning or caution. It means attention!!! Your safety is involved.
	Read Your Operator's Manual	Your manual contains special messages to bring attention to potential safety concerns as well as operating and servicing information. Please read all the information carefully to ensure satisfaction and safe use.
	Wear Hearing Protection	Hearing protection must be worn when operating this equipment.
	Risk of Bursting	Air and condensation water can burst from the compressor when the drain plug is removed.
	Do Not Pull Out The Plug.	To stop the compressor, use the switch located on the pressure switch body. Never use the main switch or unplug the compressor.
	Risk of Electric Shock	Hazardous Voltage. Disconnect from power source before servicing. Do not use in damp conditions.
	Hot Surface	To reduce the risk of injury or damage, avoid contact with any hot surface.
	Enclosure Alert	Do not operate the portable compressor with the doors or enclosure open.
	Unexpected Starting	The compressor may start without warning.
	Oil	Use SAE-30 non-detergent (API CG/CD Heavy Duty) oil.
	Recycle Symbol	Waste electrical products should not be disposed of with household waste. Please recycle where facilities exist. Check with your Local Authority or retailer for recycling advice.
	CE Marking	Conforms to relevant safety standards.

NOTES

NOTES

NOTES

RYOBI POWER EQUIPMENT WARRANTY

Subject to the warranty conditions below, this RYOBI tool (hereinafter called "the Product"), is warranted by Ryobi (herein called "the Company") to be free from defects in material or workmanship for a period of 24 months from the date of original purchase covering both parts and labour. Under the terms of this warranty, the repair or replacement of any part shall be the opinion of the Company or its authorised agent. Should service become necessary during the warranty period, the owner should contact the authorised Ryobi retailer from whom the product was purchased, or the nearest Company branch office. In order to obtain warranty service, the owner must include the Sales Docket and Warranty Certificate to confirm date of purchase. This Product is sold by the dealer or agent as principal and the dealer has no authority from the Company to give any additional warranty or guarantee on the Company's behalf except as herein contained or herein referred to.

Warranty Conditions

This warranty only applies provided that the Product has been used in accordance with the manufacturer's recommendations under normal use and reasonable care (in the opinion of the Company) and such warranty does not cover consumable components, damage, malfunction or failure resulting from

misuse, neglect, abuse, or used for a purpose for which it was not designed, or is not suited and no repairs, alterations or modifications have been attempted by other than an Authorised Service Agent. This guarantee will not apply if the tool is damaged by accident or if repairs arise from normal wear and tear.

Accessories such as bits, blades, sanding discs, cutting lines, etc., are excluded from this guarantee. Normal consumable parts, such as carbon brushes, bearings, chucks, cord assembly's, spark plugs, recoil pulleys and bump head assembly's are specifically excluded from this guarantee.

The Company accepts no additional liability pursuant to this warranty for the costs of traveling or transportation of the Product or parts to and from the service dealer or agent - which costs are not included in the warranty.

Nothing herein shall have the effect of excluding, restricting or modifying any conditions, warranty, right or liability imposed, to the extent only that such exclusion, restriction or modification would render any term herein void.



STEVENS & CO (Pty) Ltd
604, 16th Street, Randjespark
Midrand, South Africa

P O Box 4059
HALFWAY HOUSE
1685, South Africa

Tel: +27 (11) 357-9600
Fax: +27 (11) 805-5541
email: stevens@ryobi.co.za

THIS WARRANTY FORM SHOULD BE RETAINED BY THE CUSTOMER AT ALL TIMES.

For your record and to assist in establishing date of purchase (necessary for in-warranty service), please keep your purchase docket and this form, completed with the following particulars.

PURCHASED FROM:.....

ADDRESS OF DEALER:.....

DATE:..... MODEL NO..... SERIAL NO.....

Present this form with your Purchase Docket when Warranty Service is required.