

RYOBI®

AJP-1100

GB OWNER'S OPERATING MANUAL

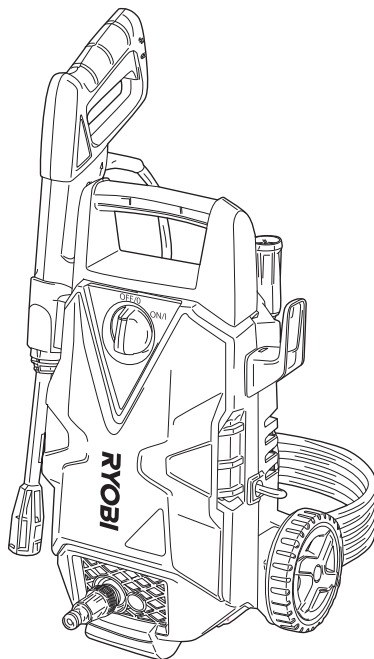

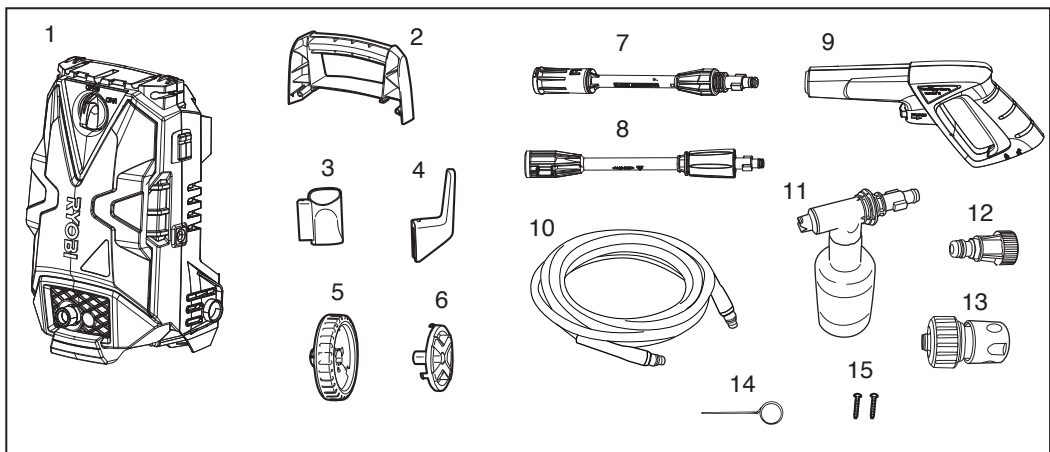

1

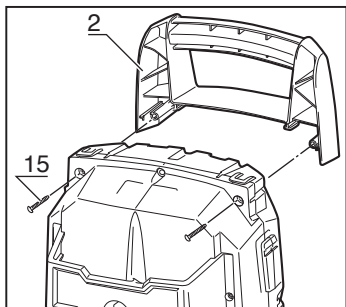

2

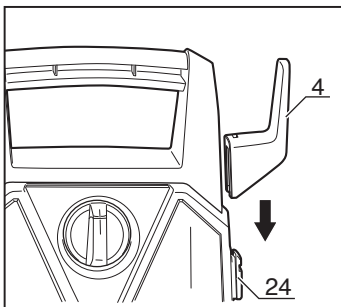

3

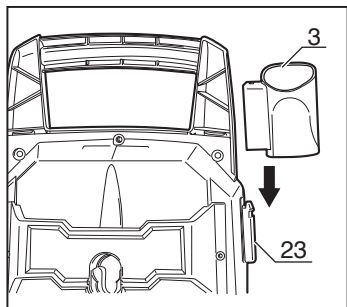

4

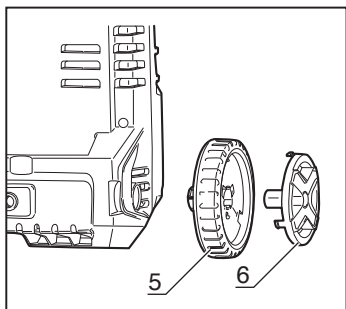

5

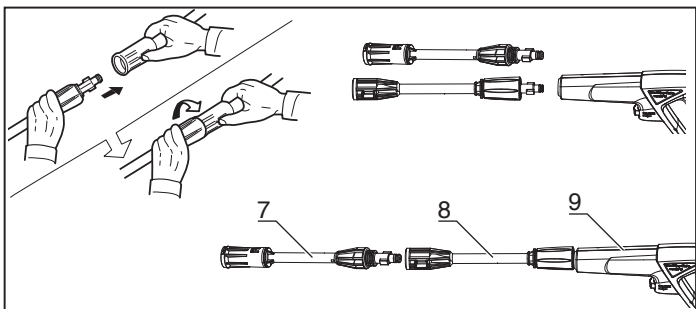

6

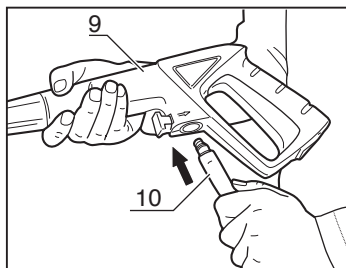

7

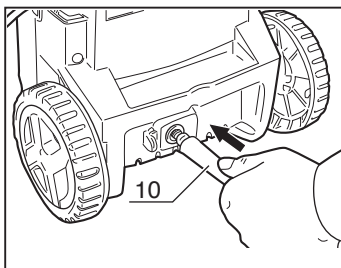

8

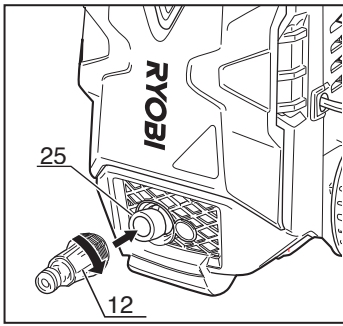

9

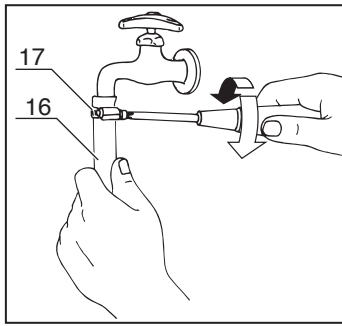

10

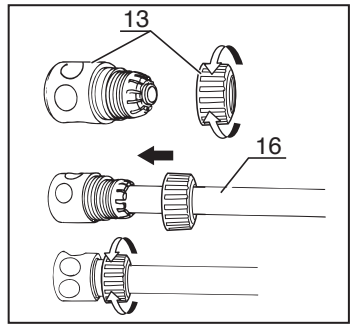

11

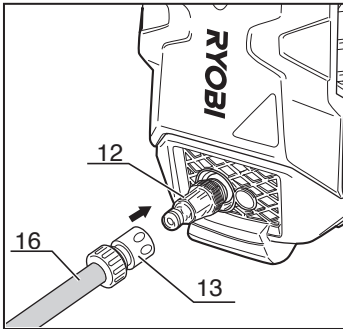

12

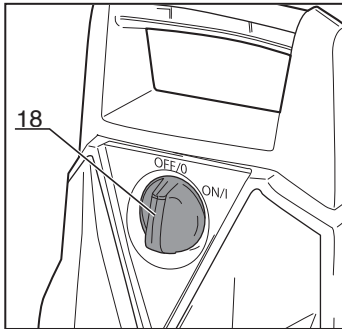

13

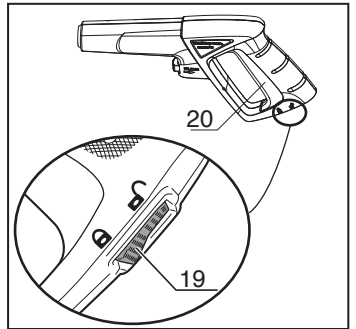

14

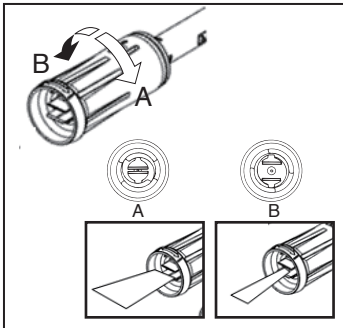

15

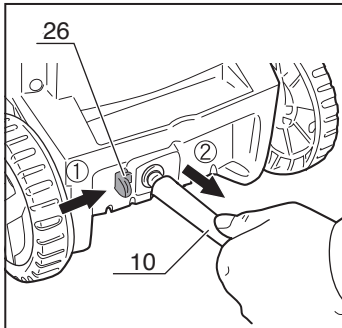

16

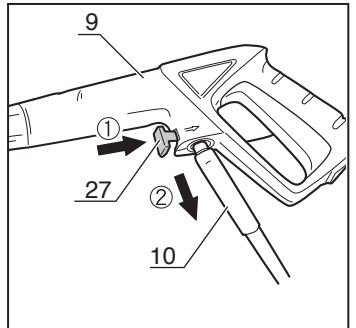

17

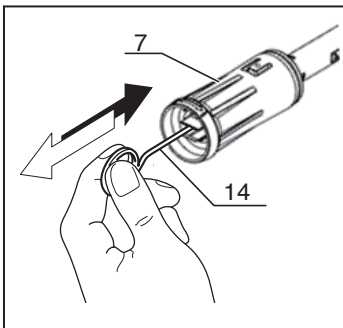

18

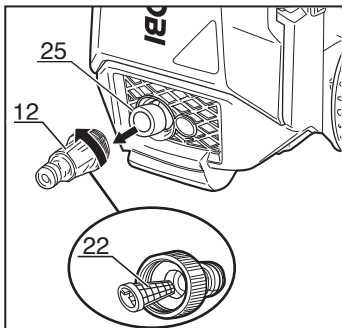

19

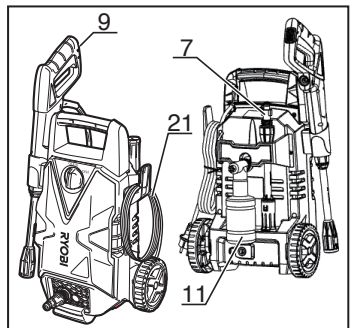

20

Carefully read and understand these instructions before operating this high pressure washer.

Package Contents (Fig.1)

1. Main unit
2. Handle
3. Spray handle holder
4. Cord hook
5. Wheel
6. Wheel cover
7. Variable nozzle lance
8. Mid nozzle lance
9. Spray handle
10. Spray handle hose (5m)
11. Detergent bottle
12. Water connector
13. Hose joint
14. Nozzle cleaning pin
15. Screw

Technical data

Power rating input	1,400 W
Rated pressure	70 bar (7 MPa)
Allowable pressure	100 bar (10 MPa)
Rated flow	5.5 L / min
Max. inlet water pressure	0.7 MPa
Max. temperature:	40°C
Adding water	From a faucet
Weight	4.5 Kg
Sound pressure level Uncertainty	LpA=77dB(A) KPA=3dB
Sound power level	LwA=92dB(A)
Vibration Value	aH=1.8m/s ² Kah=0.05m/s ²

Name of Parts:

- | | |
|--------------------------------|-------------------------|
| 1. Main unit | 17. Hose clamp (option) |
| 2. Handle | 18. Main switch |
| 3. Spray handle holder | 19. Safety lock button |
| 4. Cord hook | 20. Trigger |
| 5. Wheel | 21. Power cord |
| 6. Wheel cover | 22. Filter |
| 7. Variable nozzle lance | 23. Hook |
| 8. Mid nozzle lance | 24. Hook |
| 9. Spray handle | 25. Water inlet |
| 10. Spray handle hose | 26. Release button |
| 11. Detergent bottle | 27. Release button |
| 12. Water connector | |
| 13. Hose joint | |
| 14. Nozzle cleaning pin | |
| 15. Screw | |
| 16. Water supply hose (option) | |

Preparation

Before starting up your machine, we advise you to carefully read through this instruction manual. Follow all instructions to minimize the risk of injuries when using the machine.

Prior to operation

Before starting up your machine, please check it carefully for any defects. If you find any, do not start up your machine and contact your distributor.

Especially check:

The insulation of the electric cable should be faultless and without any cracks. If the electric cable is damaged, it should be replaced by RYOBI authorized distributor.

⚠ Mains power supply connection

The following should be observed when connecting the machine to the electric installation:

- Check before operation that the local power supply is the same as the specifications on the rating label.
- This machine is equipped with universal motor with double insulation. It is not necessary to have earth connection.
- The electric installation shall be made by a certified electrician.
- It is strongly recommended that the power supply to the machine should include a residual current device (RCD).
- Product protection degree:IPX5

General safety regulations and accident prevention

It is essential that you read the safety regulations and operating instructions in their entirety and follow the information contained therein in order to eliminate the possibility of an accident or potentially dangerous situation from occurring while working with the machine.

- The power plug must be plugged into a properly installed socket. The power supply should include a residual current device for max. 30 mA.
- Always check the device, the mains cable and the plug before using the machine. Only operate the device when it is in good working order and has not been damaged in any way. Damaged parts must be immediately replaced by a qualified electrician.
- Always pull the power plug out of the socket outlet before doing any work on the machine, before changing the nozzle and whenever it is not being used.
- **Warning!** Inadequate extension cords can be dangerous.
- If an extension cord is used, it shall be suitable for outdoor use, and the connection has to be kept dry.
- Only use suitable extension cable when working outdoors. Extension cable must have a minimum cross-section of 1.5 mm².
- **Warning!** This device was developed to be used with cleaning agents supplied or recommended by the manufacturer. The use of any other cleaning agents or chemicals can negatively affect the safety of the device.
- Cable connections should be kept dry and off the ground. Always uncoil the extension cable completely to avoid heat damage to the cable.
- **Warning!** Do not use the device when other persons or animals are in the near vicinity unless they are wearing appropriate protective clothing.

- **Warning!** High pressure jets can be dangerous when the machine is not used properly. Do not direct the jet toward persons, animals, live electrical equipment or the device itself.
- Do not direct the jet against yourself or others in order to clean clothes and footwear.
- Children should be supervised to ensure that they do not play with the machine.
- This machine is not intended for use by persons (including children) with reduced physical, sensory or mental capabilities, or lack of experience and knowledge, "High pressure cleaners shall not be used by children or untrained personnel."
- **Warning!** Spray handle hoses, fittings and couplings are important components for the safety of the device. Only use spray handle hoses, fittings and couplings that are recommended by the manufacturer.
- In order to ensure the operational safety of the device, only use genuine manufacturer's replacement parts or parts that have been approved by the manufacturer.
- Do not operate the device if the mains cable or other important parts of device – e.g. safety related elements, spray handle hose, spray pistol – are damaged.
- Do not pull or carry the electric tool by its mains cable. Protect the mains cable from becoming damaged by oil, solvents and sharp edges.
- Keep your place of work tidy.
- Ensure that the switch is turned off when connecting the machine to the power supply.
- Wear the suitable work clothes.
- Check your machine to ensure that it is in good working order. If it is not functioning properly, have it checked by an RYOBI authorized distributor. Have all maintenance and inspection work carried out only by RYOBI authorized distributor.
- The water jet that emerges from the high pressure nozzle produces a 'kickback' on the spray handle. Therefore, make sure that you have a solid footing and that you have a firm hold of the handle grip. In order to protect yourself from possible flying objects (that are released due to the high pressure).
- The high pressure jet can damage vehicle tyres and tyre parts. Keep a distance of at least 30 cm from the object being cleaned.
- If there is a power failure while you are using the machine, be sure to switch off the machine for safety reasons.
- The electric pump always must be able to draw on a sufficient supply of water. Dry operation causes severe damage to the seals.
- Disconnect from the power supply before carrying out user maintenance.
- Only use genuine spare parts from the manufacturer or approved by the manufacturer.
- If the supply cord is damaged, it must be replaced by RYOBI authorized distributor in order to avoid a hazard.
- Never use the machine in an environment where there could be a danger of explosion. If any doubt arises, please contact RYOBI authorized distributor.
- It is not allowed to clean asbestos-containing surfaces with high pressure.
- This machine must not be used at temperatures below 0°C.
- The electric supply connection (for example, connection the RCD or fix wiring) shall be made by a qualified electrician and comply with IEC60364-1: Low-voltage electrical installations.

Safety devices

Safety lock on spray handle

The spray handle features safety lock button (19). When the lock is activated, the spray handle cannot be operated.

Motor pump protection

The motor is equipped with a motor circuit breaker switch. When the motor starts to run hot, it is cut out automatically by this switch. Switch off the machine. Wait 5 ~ 10 minutes before using the device again. Try to determine the cause of the fault. If the problem repeats itself, please contact RYOBI service centre.

Operating instructions

Purpose

The machine is designed to clean vehicles, machines, buildings, facades, etc. in the private sector.

Areas of application

- Never use the machine in potentially explosive areas under any circumstances!
- The operating temperature must be between 0°C and +40°C.
- The machine consists of an assembly with a pump, which is encased in a shock absorbing housing. For an optimal working position the machine comes with a lance and a non-slip handle grip, whose shape and configuration comply with the applicable regulations.
- Do not cover or modify the lance or the spray nozzles in any way.
- **The machine is designed to be used with cold or lukewarm (max. 40°C); higher temperatures can damage the pump.**
- **Do not use water that is dirty, gritty or contains any chemical products, as these could impair operation and shorten the life of the machine.**

Assembly

- * Tools needed for assembly: Water supply hose, Hose clamp, Phillips screwdriver
- * The water supply hose must have an internal diameter of at least 13mm (1/2 in.) and must be reinforced. The water supply must be at least equal to the washer delivery capacity.

1. Screw the handle (2). (Fig.2)
2. Fit the cord hook (4) into the hook (24). Power cord can be hung. (Fig. 3)
3. Fit the spray handle holder (3) into the hook (23). Spray handle (9) can be stored. (Fig. 4)
4. Connect the wheel (5) and wheel cover (6) to the unit. (Fig.5)
5. Connecting the nozzle lance to the spray handle. (Fig.6) Fit the nozzle lance (7 and 8) into the spray handle (9) and rotating it until the two parts are completely locked. Test the connection by pulling on the nozzle.
6. Connect the spray handle hose (10) to the spray handle (9). (Fig.7)

WARNING! Water leakage may occur if the hose is not secured properly or if the connectors are not free from dirt and debris prior to connecting.



7. Connecting the spray handle hose to the water discharge nozzle. (Fig. 8)

Secure the spray handle hose (10) directly onto the water discharge nozzle.

WARNING! Jiggling the spray handle hose to the right or left when connecting, may cause water to leak from the connection area.

8. Screw the water connector (12) onto the water inlet (25). (Fig. 9)

9. Attach the water supply hose (16) to the faucet (Fig. 10)
WARNING! Remove dirt and debris from the faucet and from the outside and inside of the hose.

Allow the water from the faucet to run for a short time before attaching the hose.

Dirt or debris entering the unit may cause damage to the pump.

WARNING! Be sure to use water directly from the water faucet. Hot water (over 40°C) and water from hot springs may damage the unit.

Attach the water supply hose (16) to the water faucet with the hose clamp (17).

Tighten the clamp screw to secure the hose to the faucet.

10. Attaching the hose joint to the water supply hose (Fig.11)

Loosen and remove the hose link from the hose joint (13).

Insert the water supply hose (16) through the hose link. Insert the end of the water supply hose securely into the connecting portion of the hose joint.

Securely tighten the hose link onto the hose joint by turning the hose link clockwise.

WARNING! There is a valve attached to the hose joint. Water will not flow out of the hose until it is attached to the water connector.

11. Connecting the hose joint to the water connector (Fig.12)

Push the hose joint (13) onto the water connector (12) until you hear a 'click' sound.

WARNING! Jiggling the water supply hose to the right or left when attaching may cause water to leak from the connection area.

Operating the Switch (Fig.13)

Turning the main switch (18) clockwise to the "ON" position starts the unit. Returning the switch to the "OFF" position cuts electrical power to the unit.

Using the Spray Handle (Fig.14)

Pulling the spray handle trigger (20) releases a highly pressurized water flow. Releasing the trigger stops the flow.

The spray handle safety lock button (19) prevents accidental operation.

When locked, the trigger cannot be depressed.

Nozzle Lance (Fig. 15)

Changing the spray diffusion (narrow ⇄ wide)

Change the spray diffusion by turning the end of the variable nozzle lance clockwise for narrow spray diffusion and counterclockwise for wide spray diffusion.

Narrow spray ... Water is sprayed in a concentrated direct flow. The narrow spray setting is useful for removing stubborn grime.

Wide Spray Water is sprayed in a widely diffused flow. The wide spray setting is useful for removing dirt from large areas, washing cars, etc.

Operating the Unit

1. Ensure that the main switch (18) is in the OFF position. Plug in the power cord.
2. Turn on the water faucet to the full on position.
3. Release the spray handle safety lock button (19).
4. Water is sprayed from the nozzle when the spray handle trigger is depressed.

Before turning the main switch to the ON position, release all accumulated air from inside the hose and pump by depressing the trigger.

WARNING! Failure to remove the accumulated air from the hose and pump before turning on the main switch may result in decreased pressure and/or damage to the pump and motor.

5. Turn the main switch to the ON position after water begins to flow smoothly from the nozzle while depressing the spray handle trigger.
6. Operate the spray by depressing the spray handle trigger.

The motor stops when the spray handle trigger is released.

When the trigger is depressed, the motor resumes and pressurized spray is ejected from the nozzle.

WARNING!

- Maneuver the spray handle hose carefully over rough surfaces such as gravel, broken concrete, or crushed stone.
- Avoid excessive friction that could damage the spray handle hose when moving around objects such as fences, blocks, or bricks.
- Ensure that the spray handle hose is straight and free of any kinks or twists before using.
- During initial use, the spray stream may be intermittent and erratic while air is being dispelled from within the pump and hose. When this occurs, continue to depress the trigger until the spray stream stabilizes.
- Be sure to turn the main switch to the OFF position when leaving the unit unattended.
- When spraying, ensure that the spray handle trigger is always depressed and released for intervals lasting longer than 2 seconds in duration. Malfunction of the pressure switch may occur from spray intervals lasting less than 2 seconds.



After Use

1. Turn the main switch to the OFF position.
2. Turn the water faucet off.
3. Depress the spray handle trigger until all water has stopped flowing from the nozzle.
4. Pull the hose joint coupler forward to release the water supply hose from the water connector.
5. Depress the spray handle safety lock button to lock the trigger.
6. Press the release button (26) to remove the spray handle hose (10) from the main unit. (Fig. 16)
7. Remove remaining water from the main unit
Turn the main switch to the ON position for 1-2 seconds to discharge excess water from the spray handle hose connection port.

WARNING! Exercise caution as the released of excess water is highly pressurized

WARNING! Leaving the main switch on for longer than 2 seconds may damage the unit. Be sure to turn the main switch off immediately.

8. Unplug the power cord.
9. Remove the water supply hose from the faucet.
10. Press the release button (27) to remove the spray handle hose (10) from the spray handle (9). (Fig. 17)

WARNING!

Remove all excess water from the main unit, spray handle hose, spray handle and nozzles especially in cold weather. Storing the unit in cold temperatures without removing all excess water may damage the unit and cause malfunction.

Maintenance and storage

WARNING! Always disconnect the plug from the socket prior to maintenance or cleaning.

To ensure a long and problem free working life, please take the following advice:

- Wash off water hose, spray handle hose, spray lance and accessories before mounting.
- Clean the connectors of dust and sand.
- Rinse the detergent spraying attachment after use.

Any repair should always be made by RYOBI authorized distributor with genuine spare parts.

Nozzle Cleaning and Maintenance (Fig.18)

- Use the nozzle cleaning pin (14) to regularly clean inside the nozzle.
- Insert the nozzle cleaning pin (14) into the nozzle and remove any foreign matter lodged in the nozzle by tapping the nozzle onto a desk or table with the nozzle opening pointed downward.

If the nozzle is clogged, low spray pressure and/or malfunction of the pressure switch may result.

WARNING! Confirm that the nozzle is free of debris by removing it from the spray handle and visually inspecting inside the opening. Always clean the nozzle opening after removing it from the spray handle.

Cleaning the Filter (Fig.19)

1. Loosen the water connector (12) and remove it from the unit.
2. Remove the filter (22) in the water connector (12).
3. Rinse away any accumulated debris from the filter's mesh.
4. Return the filter to its original position.
5. Reconnect the water connector to the unit.
Ensure that the water connector is threaded straight onto the water connection port before gently rotating it in a clockwise direction. (If the connector is not threaded correctly onto the port, leaking may occur.)

Cleaning of machine vents

The machine should be kept clean so as to let cooling air pass freely through air vents.

Storing the Unit

- The hoses, nozzles, and spray handle may be stored on the main unit as shown in Figure 20.

Storage

Pump, hose and accessories should always be emptied of water prior to storing as follows:

1. Long periods of nonuse: If the machine is going to be stored for longer periods of time (i.e. over three months) in a room where frost could develop, it is recommended that the machine be filled with an antifreeze solution (similar to the antifreeze solutions used for vehicles).
2. When the device is not used for an extended period of time, lime deposits begin to form in the motor pump, which in turn can lead to starting difficulties.

NEVER START UP A FROZEN MACHINE.

Frost damages are not covered by the guarantee!

Environmental protection



Recycle unwanted materials instead of disposing of them as waste. All tools, hoses and packaging should be sorted, taken to the local recycling centre and disposed of in an environmentally safe way.



WARNING: Do not use appliance without reading the instruction sheet



Machine not suitable for connection to the potable water mains



To reduce the risk of injury, user must keep all bystanders at least 15m away.
High pressure jets can be dangerous if subject to misuse. The jet must not be directed at persons, live electrical equipment or the machine itself.

**Troubleshooting**

Fault	Cause	Remedy
The machine does not run when the ON/OFF switch and spray handle lever are pressed.	The plug is damaged. There is insufficient voltage. The pump is locked. The thermal relay has triggered.	Check the plug and fuses to see if they are okay. Manually turn over the motor. Let the motor cool down.
The machine runs, however only weak pressure is generated.	The intake filter is clogged. Air is being drawn in at the connectors. The inlet and outlet valves are clogged or worn. The diameter of the nozzle hole is too large.	Clean the filter. Check the intake connection fitting and the hose connectors. Clean or replace. Check and replace.
The operating pressure is irregular.	Air is being drawn in. The valves are clogged and worn. The seals are worn.	Check the intake connectors. Clean and replace. Check and replace.
The machine suddenly stops.	The thermal relay has triggered due to overheating.	Check the voltage. Turn off the switch and let the motor cool down for a few minutes.
Water drop from connect pars.	The seals are worn.	Check and replace (professional repair shop)
There is a loss of pressure.	The nozzle is worn. The valves are dirty or clogged. The valve seals are worn. The seals are worn. The filter is clogged.	Change the nozzle. Check, clean, exchange. Check and /or exchange. Check and /or exchange. Check and /or clean.
There is excess noise.	Air is being drawn in. The valves are worn, dirty or clogged. The bearings are worn. The water temperature is too high. The filter is dirty.	Check intake lines. Check, clean, exchange. Check and /or exchange. Lower the temperature to below 40°C. Check and /or exchange.
Expelled water is mixed with oil.	The sealing rings (water + oil) are worn.	Check and /or exchange.
Water leaks from the pump head.	The seals are worn. The O-ring of the seal set is worn.	Exchange the seal. Exchange the O-ring.
When the switch is pressed, the motor hums but does not start.	The mains voltage is lower than that specified. The pump is blocked or frozen. The extension cable is insufficient (cross section too small, cable too long)	Check to see that the extension cable is sufficient. Exchange the extension cable for one that is sufficient.

Discarding the machine

Carry out the following safety measures immediately, if you are no longer going to use the machine:

- Pull out the plug and make the machine inoperable.
- Store the machine in an area that cannot be reached by children.
- Do not use any parts from the used machine as replacement parts.
- Disassemble the machine and discard the individual parts in accordance with the regulation neforced in your area.

SAVE THESE INSTRUCTIONS

— NOTE —

— NOTE —

— NOTE —

RYOBI POWER EQUIPMENT WARRANTY

Subject to the warranty conditions below, this RYOBI tool (hereinafter called "the Product"), is warranted by Ryobi (herein called "the Company") to be free from defects in material or workmanship for a period of 24 months from the date of original purchase covering both parts and labour. Under the terms of this warranty, the repair or replacement of any part shall be the opinion of the Company or its authorised agent. Should service become necessary during the warranty period, the owner should contact the authorised Ryobi retailer from whom the product was purchased, or the nearest Company branch office. In order to obtain warranty service, the owner must include the Sales Docket and Warranty Certificate to confirm date of purchase. This Product is sold by the dealer or agent as principal and the dealer has no authority from the Company to give any additional warranty or guarantee on the Company's behalf except as herein contained or herein referred to.

Warranty Conditions

This warranty only applies provided that the Product has been used in accordance with the manufacturer's recommendations under normal use and reasonable care (in the opinion of the Company) and such warranty does not cover consumable components, damage, malfunction or failure resulting from

misuse, neglect, abuse, or used for a purpose for which it was not designed, or is not suited and no repairs, alterations or modifications have been attempted by other than an Authorised Service Agent. This guarantee will not apply if the tool is damaged by accident or if repairs arise from normal wear and tear.

Accessories such as bits, blades, sanding discs, cutting lines, etc., are excluded from this guarantee. Normal consumable parts, such as carbon brushes, bearings, chucks, cord assembly's, spark plugs, recoil pulleys and bump head assembly's are specifically excluded from this guarantee.

The Company accepts no additional liability pursuant to this warranty for the costs of traveling or transportation of the Product or parts to and from the service dealer or agent - which costs are not included in the warranty.

Nothing herein shall have the effect of excluding, restricting or modifying any conditions, warranty, right or liability imposed, to the extent only that such exclusion, restriction or modification would render any term herein void.



STEVENS & CO (Pty) Ltd

604, 16th Street, Randjespark
Midrand, South Africa

P O Box 4059
HALFWAY HOUSE
1685, South Africa

Tel: +27 (11) 357-9600

Fax: +27 (11) 805-5541

email: stevens@ryobi.co.za

THIS WARRANTY FORM SHOULD BE RETAINED BY THE CUSTOMER AT ALL TIMES.

For your record and to assist in establishing date of purchase (necessary for in-warranty service), please keep your purchase docket and this form, completed with the following particulars.

PURCHASED FROM:.....

ADDRESS OF DEALER:.....

DATE:..... MODEL NO..... SERIAL NO.....

Present this form with your Purchase Docket when Warranty Service is required.