

RYOBI®

AJP-2200GQ

GB OWNER'S OPERATING MANUAL

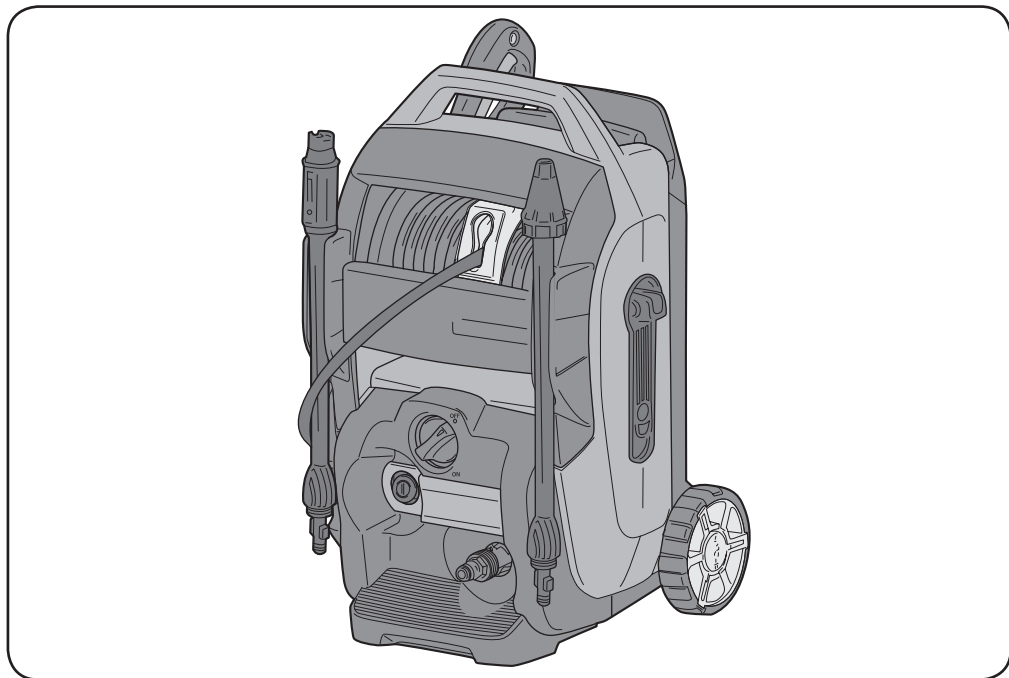

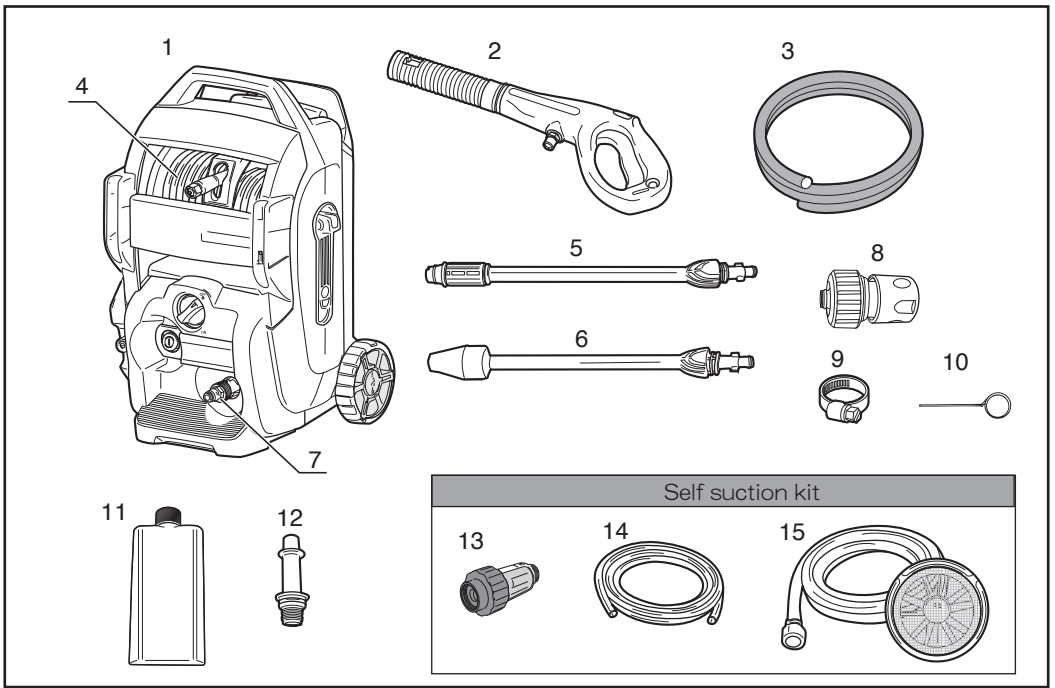

1

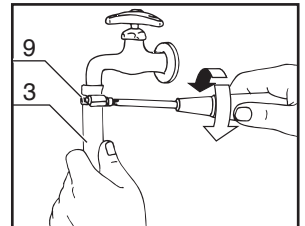
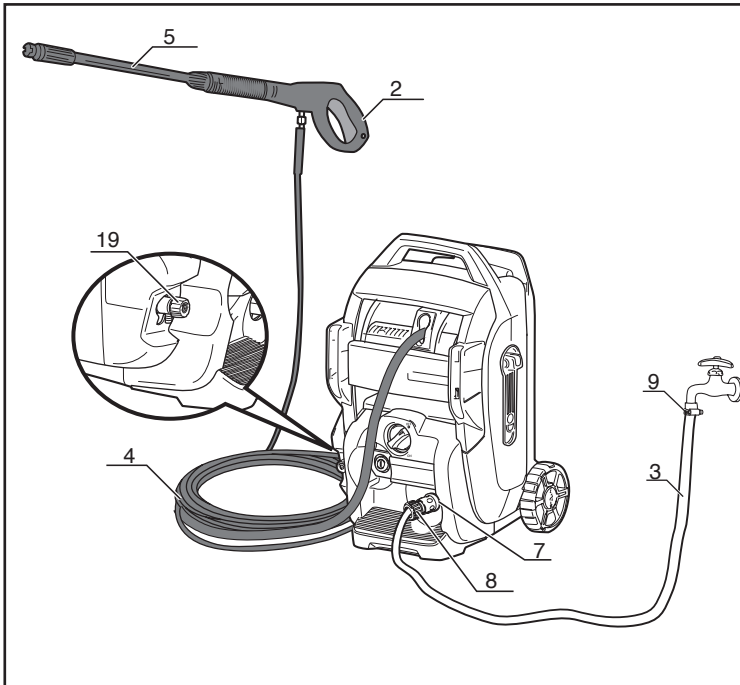

2

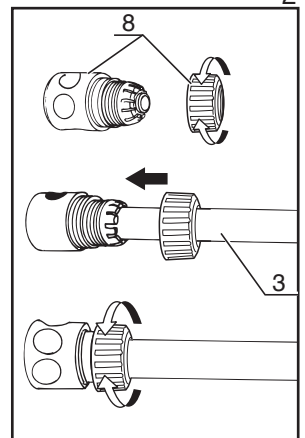

3

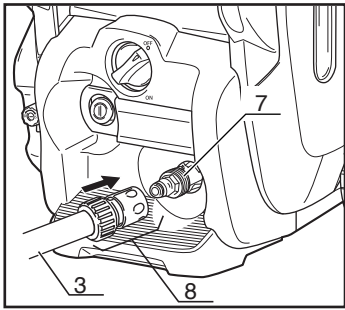

4

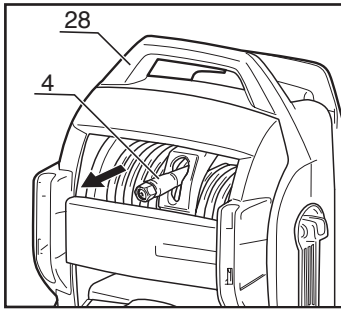

5

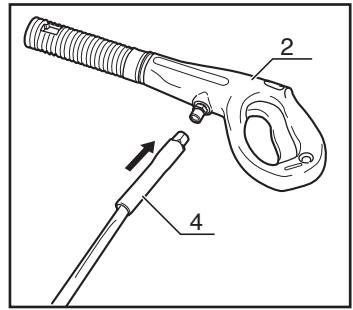

6

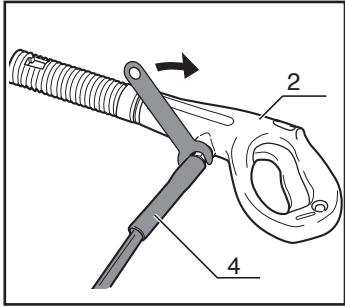

7

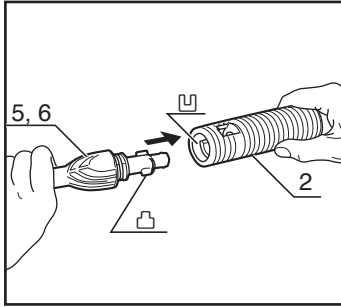

8

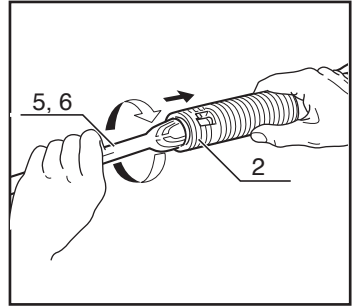

9

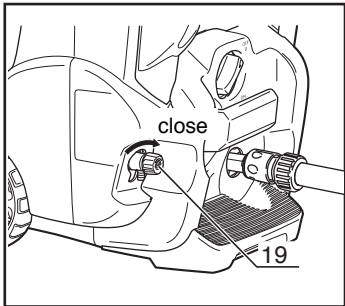

10

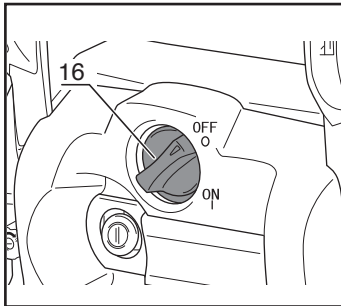

11

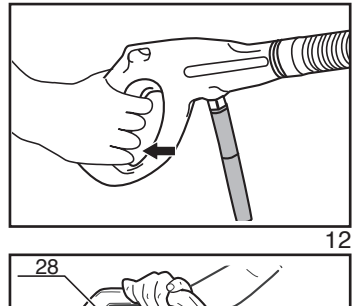

12

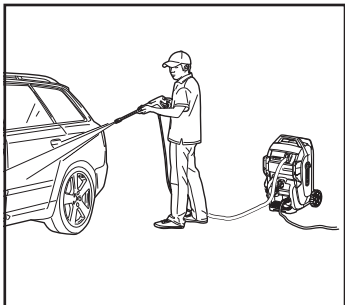

13

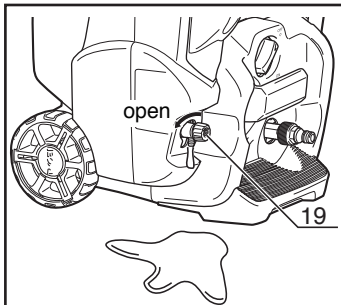

14

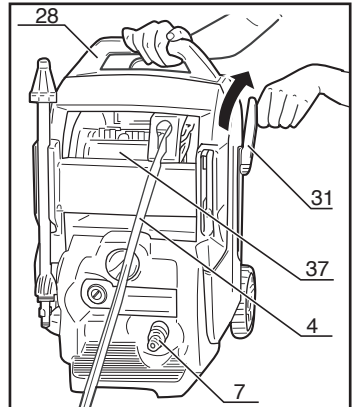

15

(Attaching the Self Suction Kit)

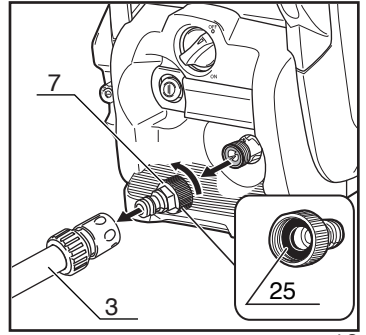
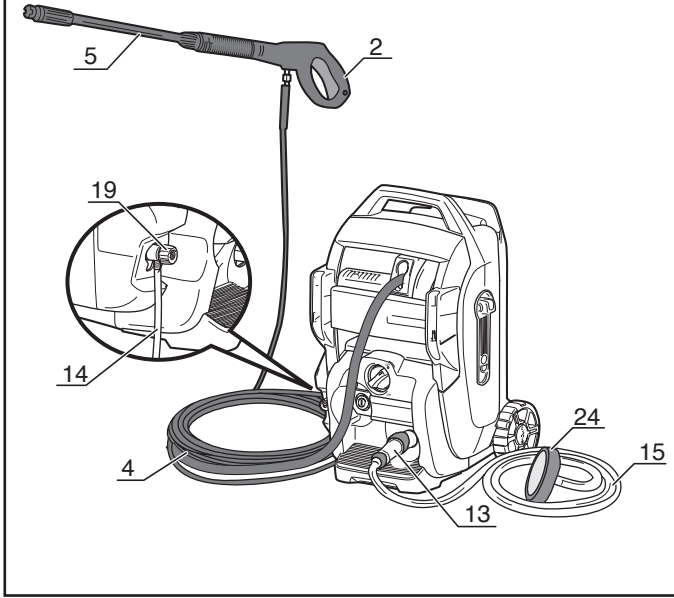

16

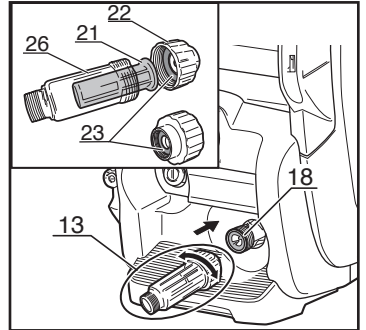

17

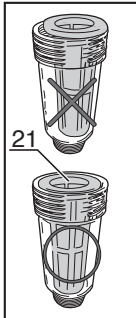

17-1

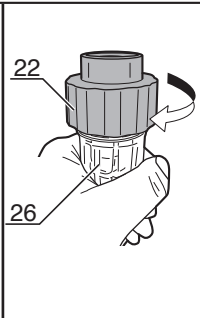

17-2

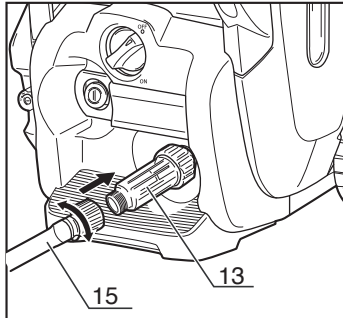

18

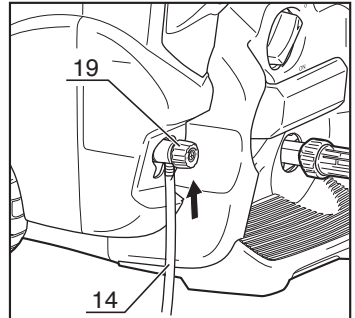

19

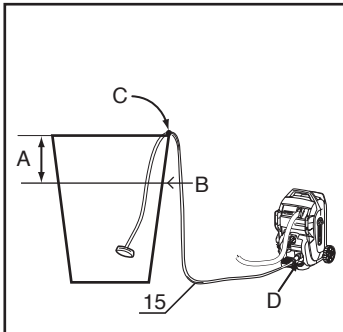

20

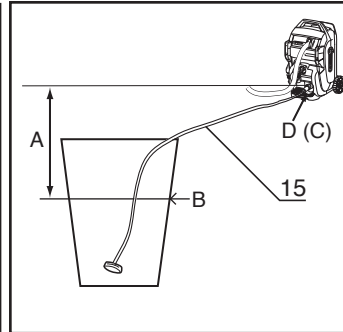

21

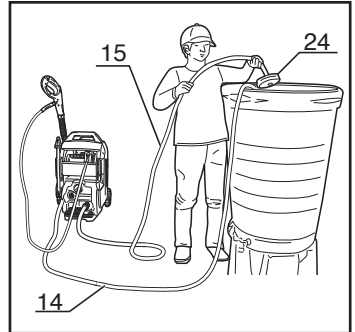

22

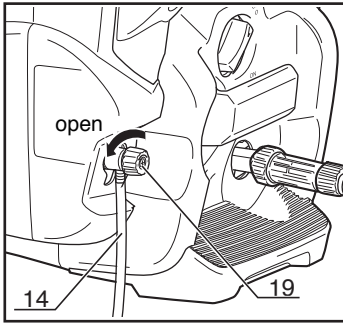

23

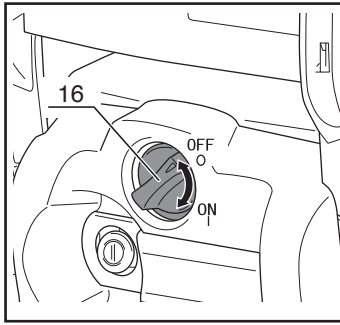

24

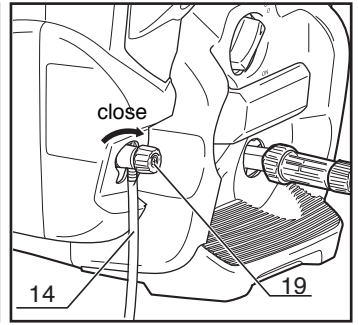

25

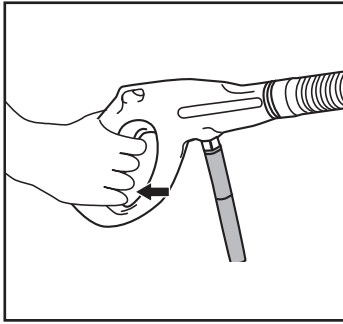

26

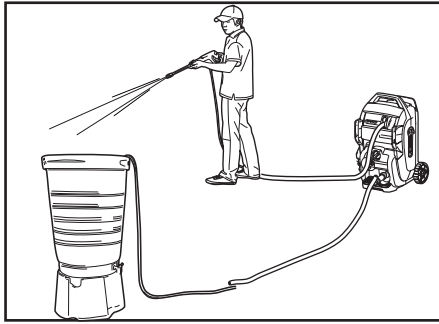

27

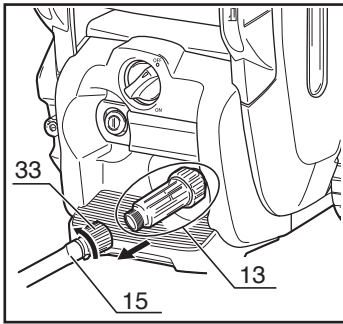

28

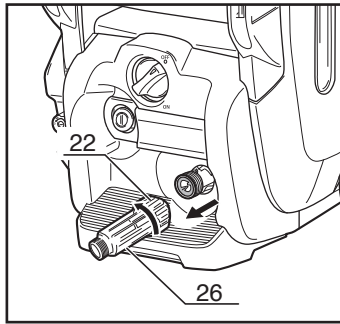

29

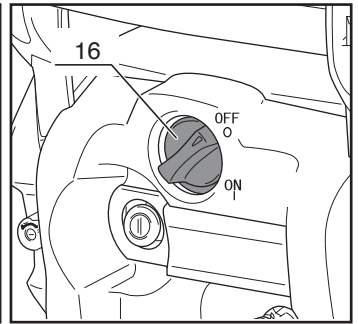

30

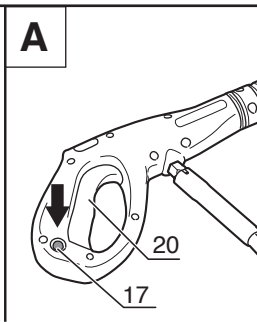
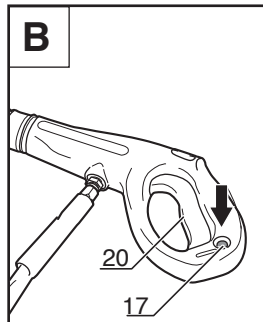

31

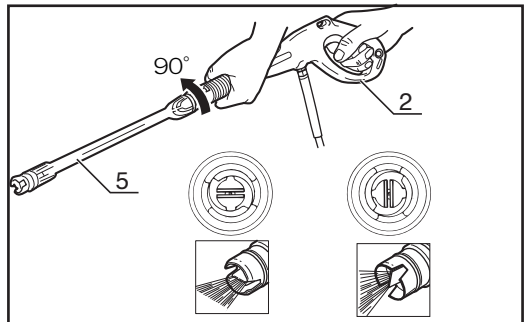

32

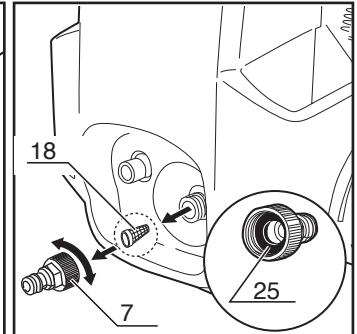
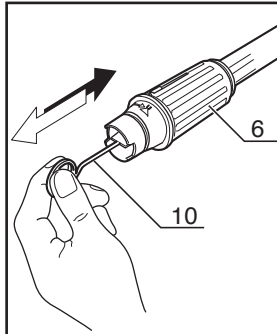
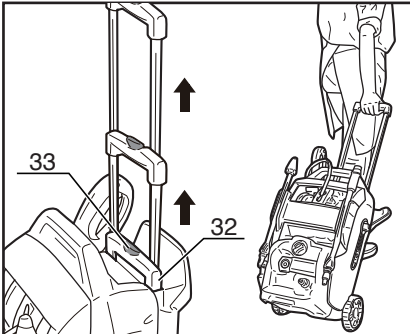
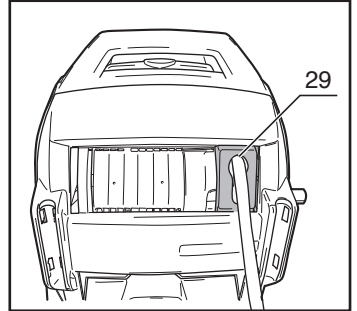
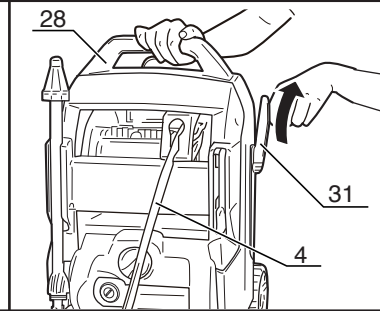
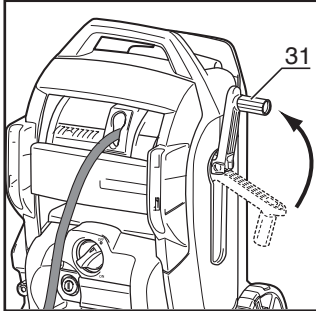
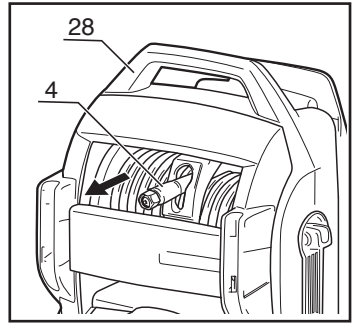
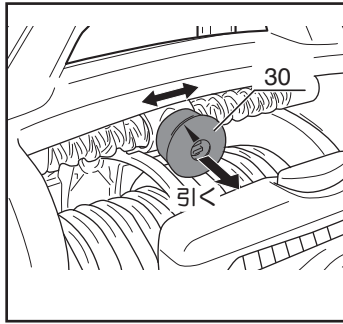
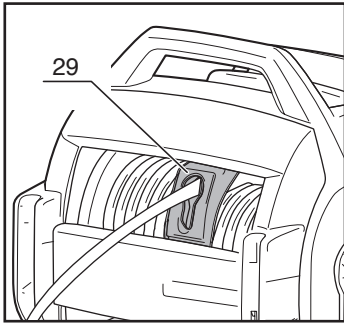
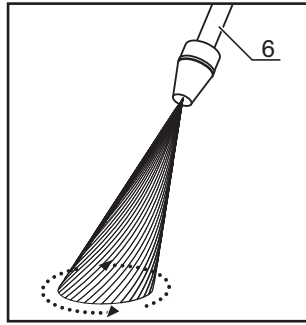
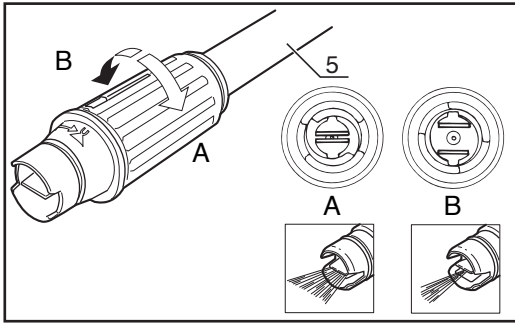

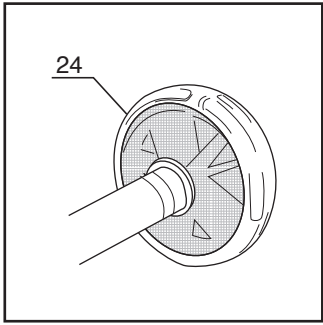

43

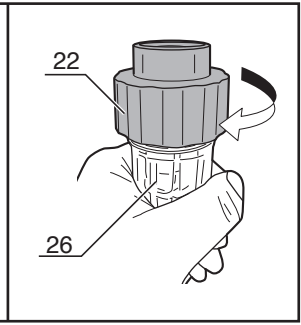
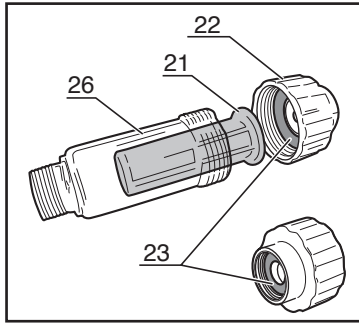

44

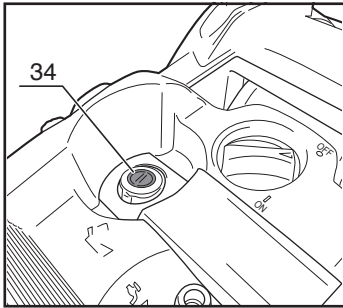

45

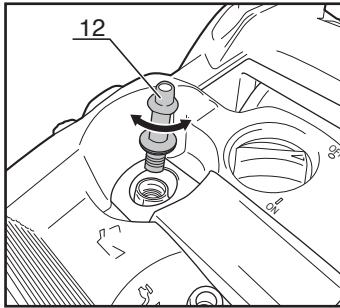

46

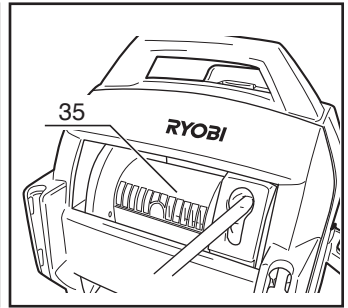

47

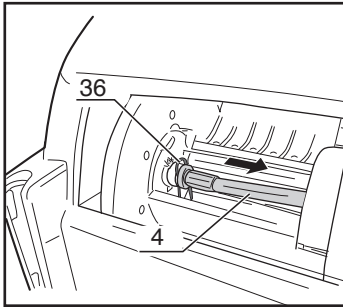

48

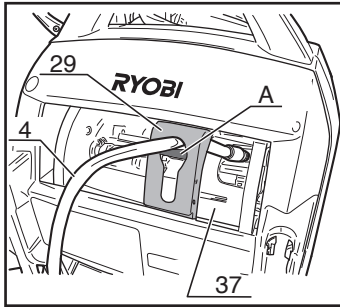

49

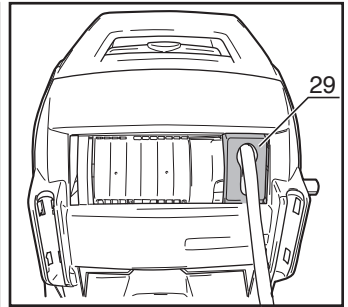

50

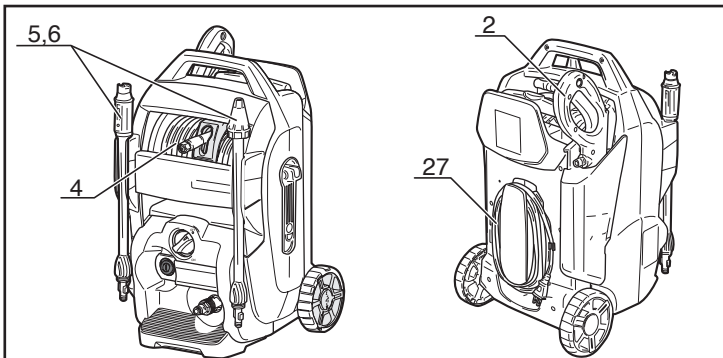

51

Carefully read and understand these instructions before operating this high pressure washer.

Package Contents (Fig.1)

1. Main unit
 2. Spray handle
 3. Water supply hose 3m
 4. Spray handle hose 15m (Main unit attachment)
 5. Variable nozzle lance
 6. Turbo nozzle lance
 7. Water connector (Main unit attachment)
 8. Hose joint
 9. Hose clamp
 10. Nozzle cleaning pin
 11. Oil (100ml)
 12. Oil nozzle
 13. Water suction filter
 14. Transparent hose
 15. Water suction hose with strainer
- } Self suction kit

Technical data

Power rating input	1,400 W
Pressure	8 MPa
Allowable pressure	12 MPa
Flow	5.0 L / min
Max. inlet water pressure	0.6 MPa
Max. temperature:	30°C
Adding water	From a faucet / water buckets
Suction Height	1m
Weight	17.8 Kg
Sound pressure level	LpA=62dB(A)
Sound power level	LwA=75dB(A)
Vibration Value	aH ≤ 2.5m/s ²

Name of Parts:

- | | |
|--------------------------------------|-----------------------|
| 1. Main unit | 21. Filter |
| 2. Spray handle | 22. Filter cap |
| 3. Water supply hose | 23. Rubber washer |
| 4. Spray handle hose | 24. Strainer |
| 5. Variable nozzle lance | 25. Rubber washer |
| 6. Turbo nozzle lance | 26. Filter case |
| 7. Water connector | 27. Power cord |
| 8. Hose joint | 28. Handle |
| 9. Hose clamp | 29. Hose guide |
| 10. Nozzle cleaning pin | 30. Guide cap |
| 11. Oil | 31. Hose reel handle |
| 12. Oil nozzle | 32. Extendable handle |
| 13. Water suction filter | 33. Button |
| 14. Transparent hose | 34. Oil cap |
| 15. Water suction hose with strainer | 35. Hose reel cover |
| 16. Main switch | 36. Fixing pin |
| 17. Safety lock button | 37. Hose reel |
| 18. Filter | |
| 19. Valve dial | |
| 20. trigger | |

Preparation

Before starting up your machine, we advise you to carefully read through this instruction manual. Follow all instructions to minimize the risk of injuries when using the machine.

Prior to operation

Before starting up your machine, please check it carefully for any defects. If you find any, do not start up your machine and contact your distributor.

Especially check:

The insulation of the electric cable should be faultless and without any cracks. If the electric cable is damaged, it should be replaced by RYOBI authorized distributor.

⚠ Mains power supply connection

The following should be observed when connecting the machine to the electric installation:

- Check before operation that the local power supply is the same as the specifications on the rating label.
- This machine is equipped with universal motor with double insulation. It is not necessary to have earth connection.
- The electric installation shall be made by a certified electrician.
- It is strongly recommended that the power supply to the machine should include a residual current device (GFCI).
- Product protection degree:IPX5

General safety regulations and accident prevention

It is essential that you read the safety regulations and operating instructions in their entirety and follow the information contained therein in order to eliminate the possibility of an accident or potentially dangerous situation from occurring while working with the machine.

- The power plug must be plugged into a properly installed socket. The power supply should include a residual current device for max. 30 mA.
- Always check the device, the mains cable and the plug before using the machine. Only operate the device when it is in good working order and has not been damaged in any way. Damaged parts must be immediately replaced by a qualified electrician.
- Always pull the power plug out of the socket outlet before doing any work on the machine, before changing the nozzle and whenever it is not being used.
- **Warning!** Unsuitable extension cable can be dangerous.
- If an extension cable is used, the plug and socket must be of watertight construction.
- Only use suitable extension cable when working outdoors. Extension cable must have a minimum cross-section of 1.5 mm².
- **Warning!** This device was developed to be used with cleaning agents supplied or recommended by the manufacturer. The use of any other cleaning agents or chemicals can negatively affect the safety of the device.
- Cable connections should be kept dry and off the ground. Always uncoil the extension cable completely to avoid heat damage to the cable.
- **Warning!** Do not use the device when other persons or animals are in the near vicinity unless they are wearing appropriate protective clothing.

- **Warning!** High pressure jets can be dangerous when the machine is not used properly. Do not direct the jet toward persons, animals, live electrical equipment or the device itself.
- Do not direct the jet against yourself or others in order to clean clothes and footwear.
- Children should be supervised to ensure that they do not play with the appliance.
- This appliance is not intended for use by persons (including children) with reduced physical, sensory or mental capabilities, or lack of experience and knowledge, unless they have been given supervision or instruction concerning use of the appliance by a person responsible for their safety.
- **Warning!** Spray handle hoses, fittings and couplings are important components for the safety of the device. Only use spray handle hoses, fittings and couplings that are recommended by the manufacturer.
- In order to ensure the operational safety of the device, only use genuine manufacturer's replacement parts or parts that have been approved by the manufacturer.
- Do not operate the device if the mains cable or other important parts of device – e.g. safety related elements, spray handle hose, spray pistol – are damaged.
- Do not pull or carry the electric tool by its mains cable. Protect the mains cable from becoming damaged by oil, solvents and sharp edges.
- Keep your place of work tidy.
- Ensure that the switch is turned off when connecting the machine to the power supply.
- Wear the suitable work clothes.
- Check your machine to ensure that it is in good working order. If it is not functioning properly, have it checked by an RYOBI authorized distributor. Have all maintenance and inspection work carried out only by RYOBI authorized distributor.
- The water jet that emerges from the high pressure nozzle produces a 'kickback' on the spray handle. Therefore, make sure that you have a solid footing and that you have a firm hold of the handle grip. In order to protect yourself from possible flying objects (that are released due to the high pressure).
- The high pressure jet can damage vehicle tyres and tyre parts. Keep a distance of at least 30 cm from the object being cleaned.
- If there is a power failure while you are using the machine, be sure to switch off the machine for safety reasons.
- The electric pump always must be able to draw on a sufficient supply of water. Dry operation causes severe damage to the seals.
- Disconnect from the power supply before carrying out user maintenance.
- Only use genuine spare parts from the manufacturer or approved by the manufacturer.
- If the supply cord is damaged, it must be replaced by RYOBI authorized distributor in order to avoid a hazard.
- Never use the machine in an environment where there could be a danger of explosion. If any doubt arises, please contact RYOBI authorized distributor.
- It is not allowed to clean asbestos-containing surfaces with high pressure.
- This machine must not be used at temperatures below 0°C.
- The electric supply connection (for example, connection the RCD or fix wiring) shall be made by a qualified electrician and comply with IEC60364-1: Low-voltage electrical installations.

- When using the self suction method, do not use a water source that contains sand or other debris.

Safety devices

Safety lock on spray handle

The spray handle features safety lock button (17). When the lock is activated, the spray handle cannot be operated.

Motor pump protection

The motor is equipped with a motor circuit breaker switch. When the motor starts to run hot, it is cut out automatically by this switch. Switch off the machine. Wait 5 ~ 10 minutes before using the device again. Try to determine the cause of the fault. If the problem repeats itself, please contact RYOBI service centre.

Using cleaning agent

Fill detergent tank with an appropriate cleaning agent, and then connect the detergent nozzle to the spray handle.

Operating instructions

Purpose

The machine is designed to clean vehicles, machines, buildings, facades, etc. in the private sector.

Areas of application

- Never use the machine in potentially explosive areas under any circumstances!
- The operating temperature must be between 0°C and +30°C.
- The machine consists of an assembly with a pump, which is encased in a shock absorbing housing. For an optimal working position the machine comes with a lance and a non-slip handle grip, whose shape and configuration comply with the applicable regulations.
- Do not cover or modify the lance or the spray nozzles in any way.
- The machine is designed to be used with cold or lukewarm (max. 30°C); higher temperatures can damage the pump.
- Do not use water that is dirty, gritty or contains any chemical products, as these could impair operation and shorten the life of the machine.

Assembly

(when using water directly from a faucet)

* Tools needed for assembly: Phillips screwdriver, 17mm wrench

1. Attach the water supply hose to the faucet (Fig. 2)

WARNING! Remove dirt and debris from the faucet and from the outside and inside of the hose.

Allow the water from the faucet to run for a short time before attaching the hose.

Dirt or debris entering the unit may cause damage to the pump.

WARNING! Be sure to use water directly from the water faucet. Hot water (over 30°C) and water from hot springs may damage the unit.

Attach the water supply hose (3) to the water faucet with the hose clamp (9).

Tighten the clamp screw to secure the hose to the faucet.

2. Attaching the hose joint to the water supply hose (Fig.3)

Loosen and remove the hose link from the hose joint (8). Insert the water supply hose (3) through the hose link. Insert the end of the water supply hose securely into the connecting portion of the hose joint.

Securely tighten the hose link onto the hose joint by turning the hose link clockwise.

WARNING! There is a valve attached to the hose joint. Water will not flow out of the hose until it is attached to the water connector.

3. Connecting the hose joint to the water connector (Fig.4)

Push the hose joint (8) onto the water connector (7) until you hear a 'click' sound.

WARNING! Jiggling the water supply hose to the right or left when attaching may cause water to leak from the connection area.

4. Connecting the spray handle hose to the spray handle (Fig.5,6,7)

Firmly hold the main unit handle (28) and pull out the end of the spray handle hose (4). (Fig.5)

Connect the spray handle hose (4) to the spray handle (2) by rotating the hose coupling. Tighten with a 17mm wrench.(Fig.6,7)

WARNING! Water leakage may occur if the hose is not secured properly or if the connectors are not free from dirt and debris prior to connecting.

5. Connecting the nozzle to the spray handle (Fig.8,9)

Insert the nozzle (5 or 6) so that it fits securely into the slotted spray handle and turn the hose nozzle clockwise while pushing firmly.

Test the connection by pulling on the nozzle.

6. Close the valve dial (Fig.10)

Rotate the knob of the valve dial (19) in the direction of the arrow and close it.

Operating the Unit

1. Ensure that the main switch (16) is in the OFF position. (Fig.11) Plug in the power cord.

2. Turn on the water faucet to the full on position.

3. Fully pull out the spray handle hose (4).

4. Release the spray handle safety lock button (17).(Fig.31-A)

5. Water is sprayed from the nozzle when the spray handle trigger is depressed. (Fig.12)

Before turning the main switch to the ON position, release all accumulated air from inside the hose and pump by depressing the trigger.

WARNING! Failure to remove the accumulated air from the hose and pump before turning on the main switch may result in decreased pressure and/or damage to the pump and motor.

6. Turn the main switch to the ON position after water begins to flow smoothly from the nozzle while depressing the spray handle trigger.

7. Operate the spray by depressing the spray handle trigger.(Fig.13)

The motor stops when the spray handle trigger is released.

When the trigger is depressed, the motor resumes and pressurized spray is ejected from the nozzle.

WARNING!

- Maneuver the spray handle hose carefully over rough surfaces such as gravel, broken concrete, or crushed stone.

- Avoid excessive friction that could damage the spray handle hose when moving around objects such as fences, blocks, or bricks.

- Ensure that the spray handle hose is straight and free of any kinks or twists before using.

- During initial use, the spray stream may be intermittent and erratic while air is being dispelled from within the pump and hose. When this occurs, continue to depress the trigger until the spray stream stabilizes.

- Be sure to turn the main switch to the OFF position when leaving the unit unattended.

- When spraying, ensure that the spray handle trigger is always depressed and released for intervals lasting longer than 3 seconds in duration.

- Malfunction of the pressure switch may occur from spray intervals lasting less than 3 seconds.

After Use

1. Turn the main switch (16) to the OFF position.

2. Turn the water faucet off.

3. Depress the spray handle trigger until all water has stopped flowing from the nozzle.

4. Pull the hose joint coupler forward to release the water supply hose from the water connector.

5. Remove the nozzle (5 or 6) from the spray handle (2).

6. Depress the spray handle trigger until all water has stopped flowing from the spray handle.

* Turn the power supply switch ON, and discharge the water in the spray handle hose.

7. Remove remaining water from the main unit (Fig.14)

Open the valve dial (19), turn the power supply switch ON, and discharge the water remaining in the main unit through the valve dial opening.

WARNING!

Leaving the power supply switch ON may cause a malfunction, so quickly turn the power supply switch OFF.

WARNING!

Store with the valve dial open.

8. Depress the spray handle safety lock button (17) to lock the trigger. (Fig.31-B)

9. Unplug the power cord.

10. Remove the water supply hose (3) from the faucet.

11. Remove the spray handle hose (4) from the spray handle (2).

12. Wind the spray handle hose

Position the end of the spray handle hose (4) lower than the hose reel (37), and wind the spray handle hose while discharging the water remaining in the spray handle hose. (Fig.15)

Refer to "Wind the spray handle hose".

13. Remove water from the main unit

Incline the main unit and discharge the water remaining inside from the water inlet.

WARNING!

Remove all excess water from the main unit, spray handle hose, spray handle and nozzles especially in cold weather. Storing the unit in cold temperatures without removing all excess water may damage the unit and cause malfunction.

When used as self-priming

Attaching the Self suction kit

1. Attaching the water suction filter to the water supply port.
 - If the water supply hose (3) or the water connectors (7) are attached, remove them. (Fig.16)

WARNING! The water supply hose (3) and the water connectors (7) is not used in self suction mode.

WARNING! Before attaching the self suction kit, thoroughly clean the water suction filter (13), the main unit filter (18), and the strainer (24). Accumulation of sand, dirt and other debris may result in decreased pressure and damage to the unit. (Fig.33, 34, 35)

- Attach the water suction filter (13) by screwing it onto the connection port. (Fig.17)

WARNING!

- a. Ensure that the water supply port and water suction filter unit contain filters (18, 21). Without filters, foreign matter may enter and damage the pump.
- b. Rubber washers (23, 25) are attached inside the water connectors and inside the water suction filter. Be careful not to lose these washers when removing them.
- c. Failure to draw water after the water suction hose has been connected, leakage after water flow has been initiated, or seepage under the main unit may be caused by the following:
 - The water suction filter connection is loose.
 - The water suction filter is not securely connected to the connection port.
 - Leakage between the filter case and the rubber washer is occurring due to the improper insertion of the filter unit into the water suction filter.

If any of the above situations have been discovered, remove the water suction filter from the main unit and reattach it according to the following instructions.

- ① Loosen the filter cap and ensure that the filter unit has been properly inserted into the filter case. (Fig.17-1)
 - ② After ensuring that the filter unit has been properly inserted into the filter case, thread the filter cap directly onto the filter case and securely tighten. (Fig.17-2)
 - ③ Thread the water suction filter directly onto the main unit connection port and securely tighten. (Fig.17)
 - ④ If water continues to leak, ensure that all of the connections have been securely tightened.
2. Attaching the water suction hose to the water suction filter (Fig. 18)
Insert the water suction hose (15) straight onto the water suction filter (13) and turn the link clockwise to fasten. Ensure that the link is tightened securely.
 3. Connect the transparent hose (14) to the valve dial (19). (Fig.19)

Connect the spray handle (2) and nozzles (5 or 6) in the same manner as when using water from the faucet (Fig.5 - Fig.9)

Suction Height

Maximum suction height is 1 meter (3 feet). Make sure that the suction height is under 1 meter (3 feet)

WARNING! Damage to the unit may result from exceeding a suction height of 1 meter (3 feet).

About Suction Height

- Suction height (A) is the distance between the water level (B) and the highest point of the water suction hose (C) when the water supply port (D) is below the water suction hose (15). (Fig.20)
- Suction height is the distance between the water supply port (D) and the water level (B) when the height of the water supply port (D) is the same as the highest point of the water suction hose. (Fig.21)

Before Getting Started

WARNING!

Filter all foreign matter (sand, dirt, debris, etc) from the water source before using it for self suction. Decreased pressure and damage to the unit may result from filters that are clogged with debris.

1. Place the strainer (24) into the water source. (Fig.22)
2. Place the end of the transparent hose (14) into the water source onto the surface to be sprayed. (Fig.22)
3. Open the valve dial (19) by turning the knob counterclockwise. (Fig.23)
4. Ensure that the main switch (16) is in the OFF position. Plug in the power cord.
5. Turn on the main switch (Fig. 24)
6. Turn off the main switch if water begins leaking from the transparent hose or if air bubbles disappear from inside the hose. (Fig.24)
7. Close the valve dial (19) knob by turning it clockwise. (Fig. 25)

A small amount of water may continue to flow out after the valve dial has been closed.

Operating the Unit

1. Fully pull out the spray handle hose (4).
2. Release the spray handle safety lock button (17). (Fig.31-A)
3. Turn on the main switch while depressing the spray handle trigger. (Fig.26)
4. Operate the unit by depressing the spray handle trigger. (Fig.27)

The motor stops when the spray handle trigger is released.

When the trigger is depressed, the motor resumes and pressurized spray is ejected from the nozzle.

WARNING!

- During initial use, the spray stream may be intermittent and erratic while accumulated air is being dispelled from within the pump and spray handle hose. When this occurs, continue to depress the trigger until the spray stream stabilizes.
- Be sure to turn the main switch to the OFF position when leaving the unit unattended.
- When spraying, ensure that the spray handle trigger is always depressed and released for intervals lasting longer than 3 seconds in duration. Malfunction of the pressure switch may occur from spray intervals lasting less than 3 seconds.

After Use

1. Turn the main switch (16) to the OFF position.
2. Remove the strainer (24) from the water supply.
3. Depress the spray handle trigger until all water has stopped flowing from the nozzle.
4. Loosen the link (33) on the water suction hose and remove it from the water suction filter (13). (Fig.28)
WARNING! Hold the water suction filter securely while loosening or tightening the link on the water suction hose. If it is not held securely, the filter cap may become loose and cause water leakage.
5. Loosen the filter cap (22) for the water suction filter (13) and remove it from the unit. (Fig.29)
WARNING! Attempting to remove the filter cap from the unit by holding and turning the filter case (26) may loosen the filter cap from the case and cause water leakage.
6. Remove the transparent hose (14) from the main unit.
7. Remove the nozzle (5 or 6) from the spray handle (2).
8. Depress the spray handle trigger until all water has stopped flowing from the spray handle.
* Turn the power supply switch ON, and discharge the water in the spray handle hose.
9. Remove remaining water from the main unit (Fig.14)
Open the valve dial (19), turn the power supply switch ON, and discharge the water remaining in the main unit through the valve dial opening.
10. Depress the spray handle safety lock button (17) to lock the trigger. (Fig.31-B)
11. Unplug the power cord.
12. Remove the spray handle hose (4) from the spray handle (2).
13. Wind the spray handle hose
Position the end of the spray handle hose (4) lower than the hose reel (37), and wind the spray handle hose while discharging the water remaining in the spray handle hose. (Fig.15)
Refer to "Wind the spray handle hose".
14. Remove water from the main unit
Incline the main unit and discharge the water remaining inside from the water inlet.
15. Thoroughly clean the water suction filter (13), the filter attached to the main unit (18) and the strainer (24)

WARNING!

Remove all excess water from the main unit, spray handle hose, spray handle and nozzles especially in cold weather. Storing the unit in cold temperatures without removing all excess water may damage the unit and cause malfunction.

Operating the Switch (Fig.30)

Turning the main switch (16) clockwise to the ON position starts the unit. Returning the switch to the OFF position cuts electrical power to the unit.

Using the the Spray Handle (Fig.31)

Pulling the spray handle trigger (20) releases a highly pressurized water flow. Releasing the trigger stops the flow. The spray handle safety lock button (17) prevents accidental operation.

When locked, the trigger cannot be depressed.

Lock the trigger by pushing the safety lock button in from the right side (Figure A). Release the lock by pushing the button from the opposite direction (Figure B).

Changing the Spray Direction (Fig.32)

The spray handle neck rotates 90 degrees.

The spray direction of the variable nozzle lance (5) can be changed during operation.

WARNING! After attached the nozzle, test the connection by pulling on the nozzle. Pushing on the nozzle while turning will detach the variable nozzle lance from the spray handle.

Variable Nozzle Lance (Fig. 33)

Changing the spray diffusion (narrow ⇔ wide)

Change the spray diffusion by turning the end of the variable nozzle lance clockwise for narrow spray diffusion and counterclockwise for wide spray diffusion.

Narrow spray ... Water is sprayed in a concentrated direct flow. The narrow spray setting is useful for removing stubborn grime.

Wide Spray Water is sprayed in a widely diffused flow. The wide spray setting is useful for removing dirt from large areas, washing cars, etc.

Turbo Nozzle Lance (Fig. 34)

The turbo nozzle lance (6) increases washing efficiency with a rotating spray.

WARNING! The turbo nozzle lance uses the narrow spray setting only.

The turbo nozzle lance emits a forceful spray that is not suitable for use on fragile items, items susceptible to surface peeling, or for washing cars.

Hose guide (Fig.35)

This device has a hose guide (29) in order to neatly wind the spray handle hose (4).

It enables the hose to be wound smoothly without any twisting.

Positioning the hose guide (Fig.36)

Pull the guide cap (30) at the back towards the front and move it to the left and right.

Pull out the spray handle hose (Fig.37)

With the hose reel handle (31) stored, hold the main unit handle (28) down and pull out the spray handle hose (4).

Wind the spray handle hose (Fig.38)

1. Take out the hose reel handle.
Lift the hose reel handle (31) in the direction of the arrow.
2. Wind the spray handle hose.
Firmly hold the main unit handle (28) and wind the hose reel handle (31) in the direction of the arrow.
* Wind the spray handle hose after removing any kinks.

If the spray handle hose cannot be neatly wound:

1. Fully pull out the spray handle hose.
2. Put the hose guide (29) at the position in fig. 39, and start winding.
3. Store the hose reel handle.



Extendable handle (Fig.40)

There is a handle that is convenient for moving the device. It can be moved by pulling out the extendable handle.

(Extending the handle)

With the button (33) pressed, pull out the extendable handle (32). Use it with the extendable handle fully pulled out.

When storing, push in with the button pressed.

* Check that the extendable handle is securely fixed.

Maintenance and storage

WARNING! Always disconnect the plug from the socket prior to maintenance or cleaning.

To ensure a long and problem free working life, please take the following advice:

- Wash off water hose, spray handle hose, spray lance and accessories before mounting.
- Clean the connectors of dust and sand.
- Rinse the detergent spraying attachment after use.

Any repair should always be made by RYOBI authorized distributor with genuine spare parts.

Nozzle Cleaning and Maintenance (Fig.41)

• Use the nozzle cleaning pin (10) to regularly clean inside the nozzle.

• Insert the nozzle cleaning pin (10) into the nozzle and remove any foreign matter lodged in the nozzle by tapping the nozzle onto a desk or table with the nozzle opening pointed downward.

If the nozzle is clogged, low spray pressure and/or malfunction of the pressure switch may result.

WARNING! Confirm that the nozzle is free of debris by removing it from the spray handle and visually inspecting inside the opening. Always clean the nozzle opening after removing it from the spray handle.

Cleaning the Filters (Fig.42)

1. Loosen the water connector (7) and remove it from the unit.
2. Remove the filter (18) attached to the water connection port with needle nose pliers.
3. Rinse away any accumulated debris from the filter's mesh.
4. Return the filter to its original position.
5. Reconnect the water connector to the unit.

Ensure that the water connector is threaded straight onto the water connection port before gently rotating it in a clockwise direction. (If the connector is not threaded correctly onto the port, leaking may occur.)

WARNING! Ensure that the rubber washer (25) is inside the water connector before attaching the water connector. Attaching the connector without the washer may cause leaking.

Cleaning the Strainer (Fig.43)

(When used as self-priming)

Rinse any accumulated debris from the strainer mesh.

WARNING! A clogged strainer may cause low spray pressure.

Cleaning the Water suction filter (Fig.44)

(When used as self-priming)

1. Remove the filter cap (22) and remove the filter (21) from the filter case (26).
2. Rinse accumulated debris away from the filter mesh.
3. Return the filter to the filter case and attach the filter cap.

WARNING!

- Be careful not to lose the rubber washers (23) located on the inside and top portion of the filter cap.
- Ensure that the filter unit is correctly inserted into the filter case before attaching the filter cap. (The inserted filter unit should not extend beyond the filter case opening). Hold the filter case parallel with the cap above, and thread the cap directly onto the filter case. If the filter is not inserted correctly, leakage or low spray pressure may occur.
- A clogged filter may cause low spray pressure.

Replace the pump oil (Fig.45, 46)

WARNING!

As the pump and pump oil are hot immediately after operation, there is a danger of getting burnt. Replace the oil after cooling sufficiently.

- The device is shipped with pump oil in it.
- Use the following as a guide for the frequency to replace the oil.
 - First time --- 30 hours
 - Subsequent times --- 300 hours
- Use the supplied oil to replace the first time, and purchase Ryobi genuine oil for subsequent replacements.

(How to replace)

WARNING!

Do not top up with oil. If the appropriate volume (100 ml) is exceeded, it may cause a malfunction.

1. Tilt the main unit backwards, and remove the oil cap (34) after loosening it with a coin, etc.
WARNING! If the oil cap is removed with the main unit upright, oil may flow out of the oil inlet.
2. Attach the oil nozzle (12) to the oil inlet.
3. Tilt the main unit forwards, and pour out all the oil.
4. Remove the oil nozzle.
5. Pour in new oil (100 ml) through the oil inlet.
6. Attach the oil cap.
Securely tighten the oil cap.

Replace the spray handle hose (Fig.47, 48, 49, 50)

The spray handle hose is a consumable item. If the spray handle hose is damaged, replace it with the following procedure.

(How to replace)

1. Fully pull out the spray handle hose (4).
2. Open the hose reel cover (35).
3. Remove the spray handle hose.
Pull out the fixing pin (36), and pull out the spray handle hose in the direction of the arrow.
4. Attach the new hose.
Lower the A section of the hose guide, and pass the spray handle hose through the hose guide hole.
Pass the spray handle hose through the hose reel (37) hole, and pull it to the connection side.

5. Fix the spray handle hose to the connection.
Firmly insert the spray handle hose into the connection, and fix by inserting the fixing pin.
Pull the spray handle hose and check that it doesn't come out.
6. Close the hose reel cover.
7. Put the hose guide in the position shown in fig. 50.
8. Wind the spray handle hose.
Turn the hose reel handle and wind the spray handle hose.
Refer to "Wind the spray handle hose".

Cleaning of machine vents

The machine should be kept clean so as to let cooling air pass freely through air vents.

Storing the Unit

- The hoses, nozzles, and spray handle may be stored on the main unit as shown in Figure 51.

Storage

Pump, hose and accessories should always be emptied of water prior to storing as follows:

1. Long periods of nonuse: If the machine is going to be stored for longer periods of time (i.e. over three months) in a room where frost could develop, it is recommended that the machine be filled with an antifreeze solution (similar to the antifreeze solutions used for vehicles).
2. When the device is not used for an extended period of time, lime deposits begin to form in the motor pump, which in turn can lead to starting difficulties.

NEVER START UP A FROZEN MACHINE.

Frost damages are not covered by the guarantee!

Environmental protection



Recycle unwanted materials instead of disposing of them as waste. All tools, hoses and packaging should be sorted, taken to the local recycling centre and disposed of in an environmentally safe way.



WARNING: Do not use appliance without reading the instruction sheet



Machine not suitable for connection to the potable water mains



To reduce the risk of injury, user must keep all bystanders at least 15m away.

Troubleshooting

Fault	Cause	Remedy
The machine does not run when the ON/OFF switch and spray handle lever are pressed.	The plug is damaged. There is insufficient voltage. The pump is locked. The thermal relay has triggered.	Check the plug and fuses to see if they are okay. Manually turn over the motor. Let the motor cool down.
The machine runs, however only weak pressure is generated.	The intake filter is clogged. Air is being drawn in at the connectors. The inlet and outlet valves are clogged or worn. The diameter of the nozzle hole is too large.	Clean the filter. Check the intake connection fitting and the hose connectors. Clean or replace. Check and replace.
The operating pressure is irregular.	Air is being drawn in. The valves are clogged and worn. The seals are worn.	Check the intake connectors. Clean and replace. Check and replace.
The machine suddenly stops.	The thermal relay has triggered due to overheating.	Check the voltage. Turn off the switch and let the motor cool down for a few minutes.
Water drop from connect pars.	The seals are worn.	Check and replace (professional repair shop)
There is a loss of pressure.	The nozzle is worn. The valves are dirty or clogged. The valve seals are worn. The seals are worn. The filter is clogged.	Change the nozzle. Check, clean, exchange. Check and /or exchange. Check and /or exchange. Check and /or clean.
There is excess noise.	Air is being drawn in. The valves are worn, dirty or clogged. The bearings are worn. The water temperature is too high. The filter is dirty.	Check intake lines. Check, clean, exchange. Check and /or exchange. Lower the temperature to below 30°C. Check and /or exchange.
Expelled water is mixed with oil.	The sealing rings (water + oil) are worn.	Check and /or exchange.
Water leaks from the pump head.	The seals are worn. The O-ring of the seal set is worn.	Exchange the seal. Exchange the O-ring.
When the switch is pressed, the motor hums but does not start.	The mains voltage is lower than that specified. The pump is blocked or frozen. The extension cable is insufficient (cross section too small, cable too long)	Check to see that the extension cable is sufficient. Exchange the extension cable for one that is sufficient.

Troubleshooting

When used as self-priming

Fault	Cause	Remedy
Low water pressure. (Weak water stream) (Water comes out in spurts)	Strainer is not completely submerged (Because the water source decreases as you spray, the strainer may not be completely submerged as the water source depletes.)	Make sure that the strainer is completely submerged into the water.
	The strainer and/or water suction filter have become clogged. (Water pressure suddenly decreases when the filters become partially clogged with debris.)	Clean the strainer, water suction filter, and the water supply filter. Filter all foreign matter (sand, dirt, debris, etc) from the water source before using it for self suction.
	The valve dial has not been closed completely.	Turn the valve dial all the way to the closed position.
The motor continues to run when the spray handle trigger is released.	The valve dial has not been closed completely.	Turn the valve dial all the way to the closed position.
The motor suddenly starts up (In intervals less than 5 minutes apart) even when the spray handle trigger has not been depressed.	The valve dial has not been closed completely.	Turn the valve dial all the way to the closed position.
Self suction operation fails (Does not pump from the water source)	The strainer is not submerged into the water. (Because the water source decreases as you spray, the strainer may not be completely submerged as the water source depletes.)	Make sure that the strainer is completely submerged into the water.
	The self suction height is over 1 meter (3 feet) (Because the water source decreases as you spray, the suction height may increase to over 1 meter (3 feet) as the water source depletes.)	Add water to the source to decrease the suction height to below 1 meter (3 feet)
	The strainer and/or water suction filter have become clogged.	Clean the strainer, water suction filter, and the water supply filter. Filter all foreign matter (sand, dirt, debris, etc) from the water source before using it for self suction.
	The pressure adjustment dial is not set to the self suction position	Set the pressure adjustment dial to the self suction position
Self suction failure with water leakage or air intake from the water suction filter.	The valve dial is not open	Open the valve dial
	The water suction filter may not be properly attached to the connection port. The filter unit is not properly inserted into the water suction filter.	Remove the water suction filter from the main unit and reattach it correctly following the instructions in step C of the WARNING under "Attach the water suction filter by screwing it onto the connection port".

Discarding the machine

Carry out the following safety measures immediately, if you are no longer going to use the machine:

- Pull out the plug and make the machine inoperable.
- Store the machine in an area that cannot be reached by children.
- Do not use any parts from the used machine as replacement parts.
- Disassemble the machine and discard the individual parts in accordance with the regulation neforced in your area.

SAVE THESE INSTRUCTIONS

RYOBI POWER EQUIPMENT WARRANTY

Subject to the warranty conditions below, this RYOBI tool (hereinafter called "the Product"), is warranted by Ryobi (herein called "the Company") to be free from defects in material or workmanship for a period of 24 months from the date of original purchase covering both parts and labour. Under the terms of this warranty, the repair or replacement of any part shall be the opinion of the Company or its authorised agent. Should service become necessary during the warranty period, the owner should contact the authorised Ryobi retailer from whom the product was purchased, or the nearest Company branch office. In order to obtain warranty service, the owner must include the Sales Docket and Warranty Certificate to confirm date of purchase. This Product is sold by the dealer or agent as principal and the dealer has no authority from the Company to give any additional warranty or guarantee on the Company's behalf except as herein contained or herein referred to.

Warranty Conditions

This warranty only applies provided that the Product has been used in accordance with the manufacturer's recommendations under normal use and reasonable care (in the opinion of the Company) and such warranty does not cover consumable components, damage, malfunction or failure resulting from

misuse, neglect, abuse, or used for a purpose for which it was not designed, or is not suited and no repairs, alterations or modifications have been attempted by other than an Authorised Service Agent. This guarantee will not apply if the tool is damaged by accident or if repairs arise from normal wear and tear.

Accessories such as bits, blades, sanding discs, cutting lines, etc., are excluded from this guarantee. Normal consumable parts, such as carbon brushes, bearings, chucks, cord assembly's, spark plugs, recoil pulleys and bump head assembly's are specifically excluded from this guarantee.

The Company accepts no additional liability pursuant to this warranty for the costs of traveling or transportation of the Product or parts to and from the service dealer or agent - which costs are not included in the warranty.

Nothing herein shall have the effect of excluding, restricting or modifying any conditions, warranty, right or liability imposed, to the extent only that such exclusion, restriction or modification would render any term herein void.

RYOBI®

STEVENS & CO (Pty) Ltd
604, 16th Street, Randjespark
Midrand, South Africa

P O Box 4059
HALFWAY HOUSE
1685, South Africa

Tel: +27 (11) 357-9600
Fax: +27 (11) 805-5541
email: stevens@ryobi.co.za

THIS WARRANTY FORM SHOULD BE RETAINED BY THE CUSTOMER AT ALL TIMES.

For your record and to assist in establishing date of purchase (necessary for in-warranty service), please keep your purchase docket and this form, completed with the following particulars.

PURCHASED FROM:.....

ADDRESS OF DEALER:.....

DATE:..... MODEL NO..... SERIAL NO.....

Present this form with your Purchase Docket when Warranty Service is required.