

# RYOBI®

## G-850

GB OWNER'S OPERATING MANUAL

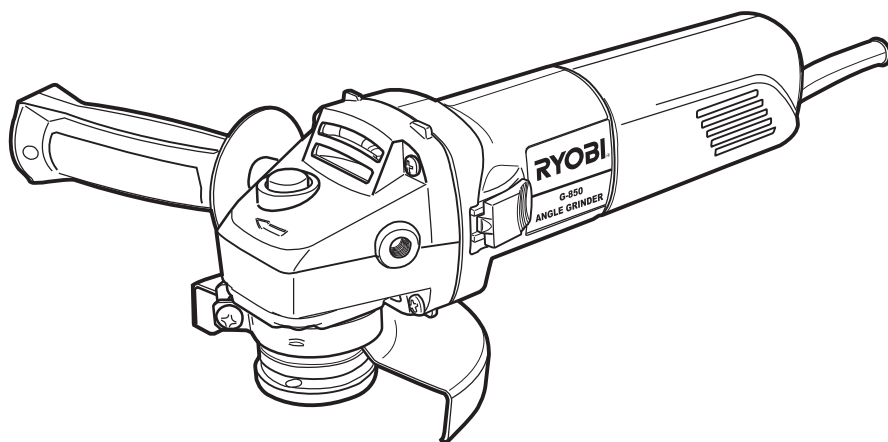

CE □

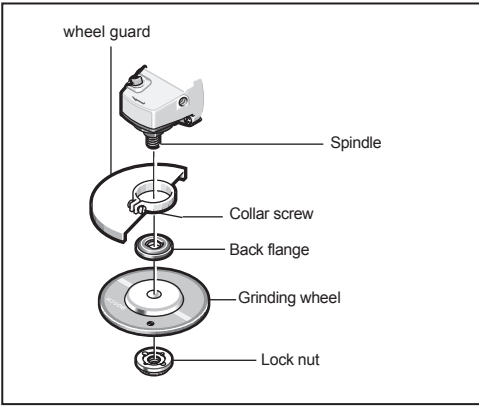
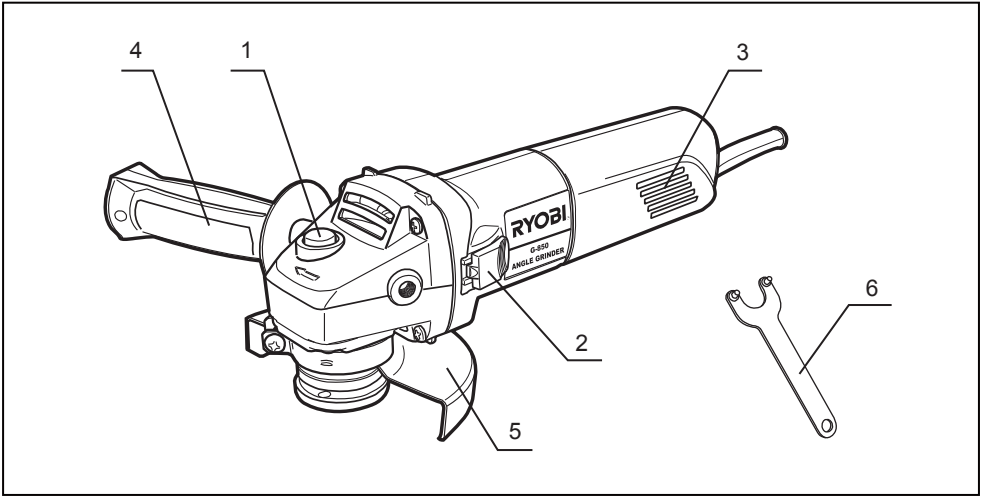

1

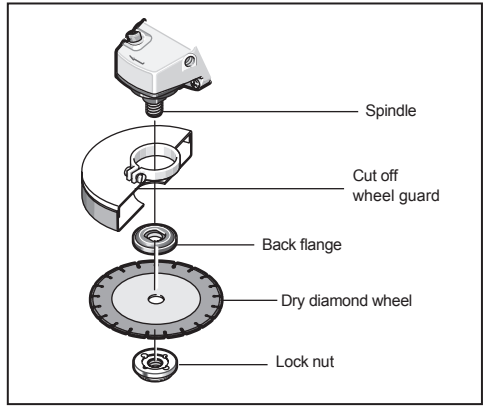

2

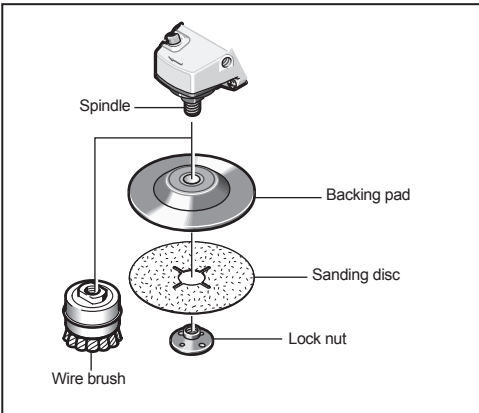

3

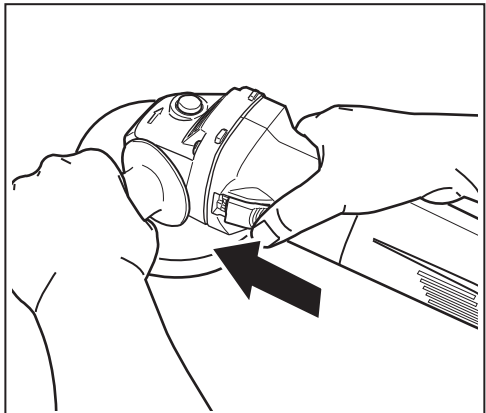

4

**THANK YOU FOR BUYING A RYOBI PRODUCT.**

To ensure your safety and satisfaction, carefully read through this OWNER'S MANUAL before using the product.

**General Safety Rules**

**WARNING!** Read all instructions. Failure to follow all instructions listed below may result in electric shock, fire and/or serious injury. The term "power tool" in all of the warnings listed below refers to your mains-operated (corded) power tool or battery-operated (cordless) power tool.

**SAVE THESE INSTRUCTIONS****1) Work area**

- a) **Keep work area clean and well lit.** Cluttered and dark areas invite accidents.
- b) **Do not operate power tools in explosive atmospheres, such as in the presence of flammable liquids, gases or dust.** Power tools create sparks which may ignite the dust or fumes.
- c) **Keep children and bystanders away while operating a power tool.** Distractions can cause you to lose control.

**2) Electrical safety**

- a) **Power tool plugs must match the outlet. Never modify the plug in any way. Do not use any adapter plugs with earthed (grounded) power tools.** Unmodified plugs and matching outlets will reduce risk of electric shock
- b) **Avoid body contact with earthed or grounded surfaces such as pipes, radiators, ranges and refrigerators.** There is an increased risk of electric shock if your body is earthed or grounded.
- c) **Do not expose power tools to rain or wet conditions.** Water entering a power tool will increase the risk of electric shock.
- d) **Do not abuse the cord. Never use the cord for carrying, pulling or unplugging the power tool. Keep cord away from heat, oil, sharp edges or moving parts.** Damaged or entangled cords increase the risk of electric shock.
- e) **When operating a power tool outdoors, use an extension cord suitable for outdoor use.** Use of a cord suitable for outdoor use reduces the risk of electric shock.

**3) Personal safety**

- a) **Stay alert, watch what you are doing and use common sense when operating a power tool. Do not use a power tool while you are tired or under the influence of drugs, alcohol or medication.** A moment of inattention while operating power tools may result in serious personal injury.
- b) **Use safety equipment. Always wear eye protection.** Safety equipment such as dust mask, non-skid safety shoes, hard hat, or hearing protection used for appropriate conditions will reduce personal injuries.

- c) **Avoid accidental starting. Ensure the switch is in the off-position before plugging in.** Carrying power tools with your finger on the switch or plugging in power tools that have the switch on invites accidents.
- d) **Remove any adjusting key or wrench before turning the power tool on.** A wrench or a key left attached to a rotating part of the power tool may result in personal injury.
- e) **Do not overreach. Keep proper footing and balance at all times.** This enables better control of the power tool in unexpected situations.
- f) **Dress properly. Do not wear loose clothing or jewellery. Keep your hair, clothing and gloves away from moving parts.** Loose clothes, jewellery or long hair can be caught in moving parts.
- g) **If devices are provided for the connection of dust extraction and collection facilities, ensure these are connected and properly used.** Use of these devices can reduce dust-related hazards.

**4) Power tool use and care**

- a) **Do not force the power tool. Use the correct power tool for your application.** The correct power tool will do the job better and safer at the rate for which it was designed.
- b) **Do not use the power tool if the switch does not turn it on and off.** Any power tool that cannot be controlled with the switch is dangerous and must be repaired.
- c) **Disconnect the plug from the power source before making any adjustments, changing accessories, or storing power tools.** Such preventive safety measures reduce the risk of starting the power tool accidentally.
- d) **Store idle power tools out of the reach of children and do not allow persons unfamiliar with the power tool or these instructions to operate the power tool.** Power tools are dangerous in the hands of untrained users.
- e) **Maintain power tools. Check for misalignment or binding of moving parts, breakage of parts and any other condition that may affect the power tools operation. If damaged, have the power tool repaired before use.** Many accidents are caused by poorly maintained power tools.
- f) **Keep cutting tools sharp and clean.** Properly maintained cutting tools with sharp cutting edges are less likely to bind and are easier to control.
- g) **Use the power tool, accessories and tool bits etc., in accordance with these instructions and in the manner intended for the particular type of power tool, taking into account the working conditions and the work to be performed.** Use of the power tool for operations different from intended could result in a hazardous situation.

**5) Service**

- a) **Have your power tool serviced by a qualified repair person using only identical replacement parts.** This will ensure that the safety of the power tool is maintained.

**ANGLE GRINDER SAFETY PRECAUTIONS**

- 1. ALWAYS USE PROPER GUARD WITH GRINDING WHEEL.** A guard protects operator from broken wheel fragments. When using grinding wheel attachments, the guard must always be attached to the tool and positioned for maximum safety, so the least amount of wheel is exposed from the side the tool is being operated.
- 2. ACCESSORIES MUST BE RATED FOR AT LEAST THE SPEED RECOMMENDED ON THE TOOL WARNING LABEL.** Wheels and other accessories running over rated speed can fly apart and cause injury. Grinding wheels or any other accessory must have a maximum safe operating speed greater than the “no load speed” marked on the tool’s nameplate.
- 3. HOLD TOOL BY INSULATED GRIPPING SURFACES WHEN PERFORMING AN OPERATION WHERE THE CUTTING TOOLS MAY CONTACT HIDDEN WIRING OR ITS OWN CORD.** Contact with a “live” wire will make exposed metal parts of the tool “live” and shock the operator.
- 4. BEFORE USING A GRINDER OR INSTALLING A NEW WHEEL, INSPECT THE GRINDING WHEEL FOR CHIPS AND CRACKS.** Remove bad wheels immediately. Run the tool at no load for one minute, holding the tool in the direction away from people. Wheels with flaws will normally break apart during this time.
- 5. CAREFULLY HANDLE BOTH THE TOOL AND INDIVIDUAL GRINDING WHEELS TO AVOID CHIPPING OR CRACKING.** Install a new wheel if tool is dropped while grinding. Do not use a wheel that may be damaged. Fragments from a wheel that bursts during operation will fly away at great velocity possibly striking you or bystanders.
- 6. DO NOT USE GRINDING WHEEL THAT IS LARGER THAN THE MAXIMUM RECOMMENDED SIZE FOR YOUR TOOL, OR WORN DOWN DAMAGED WHEELS FROM LARGER GRINDERS.** Wheels intended for large angle sander/grinders are not suitable for the high speed of a small angle sander/grinder, these wheels may easily burst and the fragments strike you or bystanders.
- 7. DO NOT USE DEPRESSED HUB GRINDING WHEELS FOR CUT-OFF OPERATIONS.**
- 8. DO NOT USE THIS TOOL WITH “WOODCARVING” BLADE.** Such blades create frequent kick-back and loss of control.
- 9. WEAR PROPER APPAREL WHILE USING A SANDER/GRINDER.** Face shield or at least safety goggles, dust mask, leather gloves and shop apron capable of stopping small wheel or workpiece fragments.
- 10. POSITION THE CORD CLEAR OF THE SPINNING GRINDING WHEEL OR ANY OTHER SANDING ACCESSORY.** Do not wrap the cord around your arm or wrist. If you lose control and have the cord wrapped around your arm or wrist it may entrap you and cause injury.
- 11. AVOID BOUNCING AND SNAGGING THE WHEEL, ESPECIALLY WHEN WORKING CORNERS, SHARP EDGES ETC.** This can cause loss of control and kick-back.
- 12. REGULARLY CLEAN THE TOOL’S AIR VENTS BY COMPRESSED AIR.** Excessive accumulation of powdered metal inside the motor housing may cause electrical failures.
- 13. DO NOT GRIND OR SAND NEAR FLAMMABLE MATERIALS.** Sparks from the wheel could ignite these materials.
- 14. THIS TOOL CAN BE CONVERTED TO A SANDER.** When grinding is resumed the proper guard and wheel flanges **MUST** be reinstalled before proceeding with grinding. The guard must always be attached to the tool and positioned for maximum safety, so the least amount of wheel is exposed from the side the tool is being operated. The grinding wheel guard cannot be used for most sanding operations or for wire brushing.
- 15. WHEN SANDING, DO NOT USE OVERSIZED SANDING DISC.** Larger sanding disc will extend beyond the sanding pad causing snagging, tearing of the disc or kick-back. Extra paper extending beyond the sanding pad can also cause serious lacerations.
- 16. WHEN SANDING CHEMICALLY PRESSURE TREATED LUMBER, PAINT THAT MAY BE LEAD BASED, OR ANY OTHER MATERIALS THAT MAY CONTAIN CARCINOGENS, USE SPECIAL PRECAUTIONS.** A suitable breathing respirator must be worn by all personal entering the work area. Work area should be sealed by plastic sheeting and persons not protected should be kept out until work area is thoroughly cleaned.
- 17. DIRECT THE DISCHARGE OF THE SPINNING WIRE BRUSH AWAY FROM YOU.** Small particles and tiny wire fragments may be discharged at high velocity during the “cleaning” action with these brushes and may become imbedded in your skin.  
**WARNING!**  
Some dust created by power sanding, sawing, grinding, drilling, and other construction activities contains chemicals known to cause cancer, birth defects or other reproductive harm. Some examples of these chemicals are:
  - Lead from lead-based paints.
  - Crystalline silica from bricks and cement and other masonry products.
  - Arsenic and chromium from chemically treated lumber.Your risk from these exposures varies, depending on how often you do this type of work. To reduce your exposure to these chemicals: work in a well ventilated area, and work with approved safety equipment, such as those dust masks that are specially designed to filter out microscopic particles.

## INSTRUCTIONS FOR SAFE HANDLING

1. Make sure that the tool is only connected to the voltage marked on the name plate.
2. Never use the tool if its cover or any bolts are missing. If the cover or bolts have been removed, replace them prior to use. Maintain all parts in good working order.
3. Always secure tools when working in elevated positions.
4. Never touch the blade, drill bit, grinding wheel or other moving parts during use.
5. Never start a tool when its rotating component is in contact with the workpiece.
6. Never lay a tool down before its moving parts have come to a complete stop.
7. **ACCESSORIES:** The use of accessories or attachments other than those recommended in these instructions might present a hazard.
8. **REPLACEMENT PARTS:** When servicing use only identical replacement parts.

## DESCRIPTION

1. Spindle lock
2. Switch button
3. Rear motor housing
4. Side handle
5. Wheel guard
6. Lock nut spanner

## SPECIFICATIONS

<b>Voltage</b>	230V ~ 50Hz
<b>Power input</b>	850W
<b>No load speed</b>	11,000min <sup>-1</sup>
<b>Grinding wheel</b>	115mm
<b>Spindle thread</b>	M14x2.0
<b>Disk bore size</b>	22mm
<b>Net weight</b>	2.0kg

## ASSEMBLY

### WHEEL GUARD INSTALLATION

#### **WARNING!**

Wheel guard must be attached when using disc grinding wheels. Always keep wheel guard between you and your work while grinding.

To attach the wheel guard **DISCONNECT** tool from power source.

Position the guard on spindle neck, then secure guard with the collar screw.

### LOCK NUT AND BACKING FLANGE

Your tool is equipped with a threaded spindle for mounting accessories. Always use the supplied lock nut (and backing flange) that has same thread size as spindle.

### SIDE HANDLE

The side handle used to guide and balance the tool can be threaded into the front housing on either side of the tool, depending on personal preference and comfort. Use the side handle for safe control and ease of operation.

### DISC GRINDING WHEEL ASSEMBLY (Fig. 1)

Disconnect tool from power source. Be sure that wheel guard is in place for grinding. Thread **BACKING FLANGE** onto spindle, then place **GRINDING WHEEL** on the spindle. Thread on the lock nut and tighten nut using the supplied lock nut spanner, while holding the spindle lock in.  
**TO REMOVE:** Reverse procedure.

### MASONRY CUTTING WHEEL ASSEMBLY (Fig. 2)

For cutting masonry materials like brick, tile, stone, etc., it is best to use a dry diamond cutting wheel.  
Use only lock nut and flange with equal diameters.

**WARNING!** Do not use water or other cooling fluid with this tool for cutting.

**WARNING!** When using an abrasive cut-off wheel, be sure to use only the special wheel guard designed for use with cut-off wheels. Never use cut-off wheel for side grinding.

Disconnect tool from power source before attaching cutting wheel. With cut off wheel guard in place, assemble flange, cutting wheel and lock nut. When cutting, make only small passes through workpiece at a time.

Be aware that "Kickback" can occur at any time. Keep both hands on tool for maximum control.

### SANDING ACCESSORIES ASSEMBLY

**WARNING!** Before attaching a backing pad be sure its maximum safe operating speed is not exceeded by the nameplate speed of the tool.

**WARNING!** Wheel guard may not be used for most sanding operations. Always reinstall wheel guard when converting back to grinding operations.

### TO INSTALL BACKING PAD AND SANDING DISC (Fig. 3)

Disconnect tool from power source. Set the tool on its top side (spindle up). Place the rubber backing pad onto the spindle shaft. Center the sanding disc on top of the backing pad. Insert the lock nut through the disc and thread onto the spindle as far as you can with your fingers. Press in the spindle lock, then tighten the backing pad securely with the lock nut spanner.

### TO REMOVE BACKING PAD AND SANDING DISC

Disconnect tool from power source. Using the lock nut spanner unscrew the nut from the spindle, while holding spindle lock in.

### WIRE BRUSH ASSEMBLY

Before assembling wire brush to this tool, disconnect from the power source. Wire brushes are equipped with their own threaded hub, simply thread on to spindle. Be sure to seat against shoulder before turning tool "ON".

**OPERATION**

**SLIDE ON-OFF SWITCH WITH LOCK (Fig. 4)**

The tool is switched "ON" by the switch button located at the top of the motor housing. The switch can be locked in the "ON" position, a convenience for long grinding operations.

To turn the tool "ON" without locking it, slide the switch button forward by applying pressure ONLY at the REAR portion of the button. When pressure is released the switch button will snap to "OFF" position.

To lock the switch "ON", slide the switch button forward and press "IN" the FRONT portion.

To unlock the switch, simply press and release the REAR portion of the button. Switch is spring loaded and will snap back automatically.

**WARNING!** Hold the tool with both hands while starting the tool, since torque from the motor can cause the tool to twist.

Start the tool before applying to work and let the tool come to full speed before contacting the workpiece. Lift the tool from the work before releasing the switch. DO NOT turn the switch "ON" and "OFF" while the tool is under load; this will greatly decrease the switch life.

**GRINDING OPERATIONS**

**Selecting Grinding Wheels**

**WARNING!** Before using a grinding wheel, be certain that its maximum safe operating speed is not exceeded by the nameplate speed of the grinder. Do not exceed the recommended wheel diameter.

**Disc Grinding Wheels**

Grinding wheels should be carefully selected in order to use the grinder most efficiently. Wheels vary in type of abrasive, bond, hardness, grit size and structure. The correct type of wheel to use is determined by the job. Use disc grinding wheels for fast grinding of structural steel, heavy weld beads, steel casting, stainless steel and other ferrous metals.

**Grinding Tips**

Efficient grinding is achieved by controlling the pressure and keeping the angle between wheel and workpiece at 10° to 15°. If the wheel is flat, the tool is difficult to control. If the angle is too steep, the pressure is concentrated on a small area causing burning to the work surface.

**WARNING!** Excessive or sudden pressure on the wheel will slow grinding action and put dangerous stresses on the wheel.

When grinding with a new wheel be certain to grind while pulling tool backwards until wheel becomes rounded on its edge. New wheels have sharp corners which tend to "bite" or cut into workpiece when pushing forward.

**SANDING OPERATIONS**

**Selecting Sanding Disc**

Sanding discs are made of extremely hard and sharp aluminum oxide grits, phenol-resin bonded to a sturdy fiber backing for fast heavy-duty service and long life. The discs vary as to size and spacing of the abrasive grits. OPEN COAT (type H) — used for soft materials and on paint or varnish. CLOSED COAT (type K) —used for metal, hardwood, stone, marble and other materials.

Sanding discs range in grit from 16 (very coarse) to 180 (very fine). To obtain best results, select sanding discs carefully. Many jobs require the use of several grit sizes and at times both "open coat and closed coat" discs are required to get the job done faster. See chart for application examples.

Operation: Refinishing painted wood or metal surfaces.	
REMARKS	GRIT
To remove paint and to smooth surface irregularities.	Coarse 16-24-30
To smooth the rough sanding.	Medium 36-50-80
To remove scratches left by previous discs.	Fine 100-120
To smooth surfaces for painting, polishing or waxing.	Very fine 150-180

**SANDING TIPS**

For best results, tilt the Disc Sander at a 10° to 15° angle while sanding so that only about 1" of the surface around the edge of the disc contacts the work.

**WARNING!** If the disc (accessory) is held flat or the back edge of the disc comes in contact with the work, a violent thrust to the side may result.

If sander is tilted too much, sanding action will be too great and a rough cut surface or gouging and snagging will result.

Guide the Disc Sander with crosswise strokes. Be careful not to hold the sander in one spot too long. Do not use a circular motion, as this makes swirl marks. Test before use on scrap stock.

Do not force or apply pressure when sanding. Use only the weight of the tool for pressure. Excess pressure actually slows the tool down. If faster stock removal is desired, change to a coarser grit disc.

Remove gummy paint from metal with an "open coat" disc. Sand until sparks start to appear, then stop and change to a "closed coat" disc to remove any remaining paint.

**SANDING WOOD**

When sanding wood the direction of the disc motion at the contact point should parallel the grain as much as possible. The rapid cut of discs and the swirl type scratch pattern they occasionally create generally prohibit their use for producing the final finish.

Scratches and circular marks are usually the result of using too coarse a grit. When changing to a finer grit, move across the sanding lines that were made by a previous coarser disc.

**SANDING METAL**

When sanding automobiles or appliances, wipe the metal clean with a non-flammable solvent or commercial cleaner to remove all wax and grease. By doing this first, the sanding discs will sand better and last longer.

For heavy duty work, use a coarse grit disc first. Follow-up with a medium grit to remove scratches. To produce smooth finish, use fine grit disc.

**WIRE BRUSH OPERATIONS**

Wire brushes are intended to "clean" structural steel, castings, sheet metal, stone and concrete. They are used to remove rust, scale and paint.

**WARNING!** Avoid bouncing and snagging the wire brush, especially when working corners, sharp edges etc. This can cause loss of control and kick-back.



## MAINTENANCE

After use, check the tool to make sure that it is in top condition. It is recommended that you take this tool to a RYOBI Authorized Service Center for a thorough cleaning and lubrication at least once a year.

**DO NOT MAKE ANY ADJUSTMENTS WHILE THE MOTOR IS IN MOTION.**

**ALWAYS DISCONNECT THE POWER CORD FROM THE RECEPTACLE BEFORE CHANGING REMOVABLE OR EXPENDABLE PARTS (BLADE, BIT, SANDING PAPER ETC.), LUBRICATING OR WORKING ON THE UNIT.**

### WARNING!

To ensure safety and reliability, all repairs should be performed by an AUTHORIZED SERVICE CENTER or other QUALIFIED SERVICE ORGANIZATION.

**SAVE THESE INSTRUCTIONS FOR FUTURE REFERENCE.**



**WARNING!** To reduce the risk of injury, user must read instruction manual "

## RYOBI POWER EQUIPMENT WARRANTY

Subject to the warranty conditions below, this RYOBI tool (hereinafter called "the Product"), is warranted by Ryobi (herein called "the Company") to be free from defects in material or workmanship for a period of 24 months from the date of original purchase covering both parts and labour. Under the terms of this warranty, the repair or replacement of any part shall be the opinion of the Company or its authorised agent. Should service become necessary during the warranty period, the owner should contact the authorised Ryobi retailer from whom the product was purchased, or the nearest Company branch office. In order to obtain warranty service, the owner must include the Sales Docket and Warranty Certificate to confirm date of purchase. This Product is sold by the dealer or agent as principal and the dealer has no authority from the Company to give any additional warranty or guarantee on the Company's behalf except as herein contained or herein referred to.

### Warranty Conditions

This warranty only applies provided that the Product has been used in accordance with the manufacturer's recommendations under normal use and reasonable care (in the opinion of the Company) and such warranty does not cover consumable components, damage, malfunction or failure resulting from

misuse, neglect, abuse, or used for a purpose for which it was not designed, or is not suited and no repairs, alterations or modifications have been attempted by other than an Authorised Service Agent. This guarantee will not apply if the tool is damaged by accident or if repairs arise from normal wear and tear.

Accessories such as bits, blades, sanding discs, cutting lines, etc., are excluded from this guarantee. Normal consumable parts, such as carbon brushes, bearings, chucks, cord assembly's, spark plugs, recoil pulleys and bump head assembly's are specifically excluded from this guarantee.

The Company accepts no additional liability pursuant to this warranty for the costs of traveling or transportation of the Product or parts to and from the service dealer or agent - which costs are not included in the warranty.

Nothing herein shall have the effect of excluding, restricting or modifying any conditions, warranty, right or liability imposed, to the extent only that such exclusion, restriction or modification would render any term herein void.



**STEVENS & CO (Pty) Ltd**  
604, 16th Street, Randjespark  
Midrand, South Africa

P O Box 4059  
HALFWAY HOUSE  
1685, South Africa

Tel: +27 (11) 357-9600  
Fax: +27 (11) 805-5541  
email: [stevens@ryobi.co.za](mailto:stevens@ryobi.co.za)

### THIS WARRANTY FORM SHOULD BE RETAINED BY THE CUSTOMER AT ALL TIMES.

For your record and to assist in establishing date of purchase (necessary for in-warranty service), please keep your purchase docket and this form, completed with the following particulars.

PURCHASED FROM:.....

ADDRESS OF DEALER:.....

DATE:..... MODEL NO..... SERIAL NO.....

Present this form with your Purchase Docket when Warranty Service is required.