

# RYOBI®

## J-650V

Ⓒ OWNER'S OPERATING MANUAL

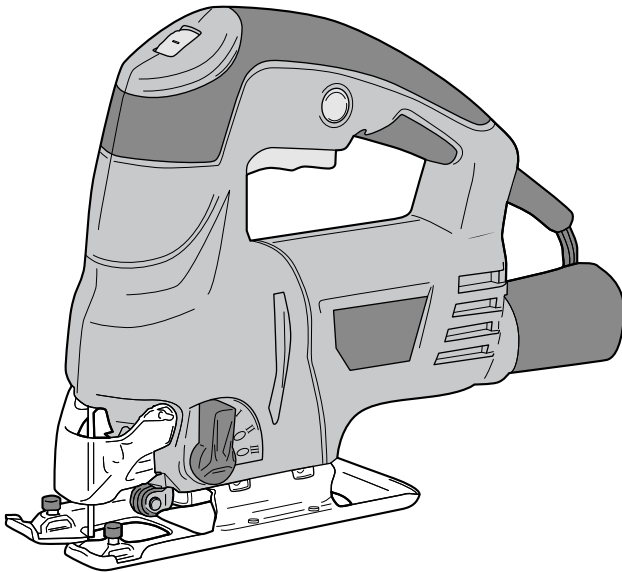

6986195 STD

11-10

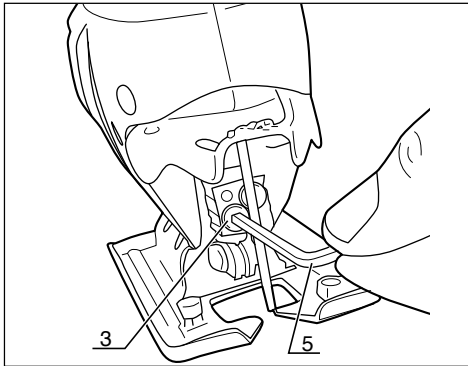
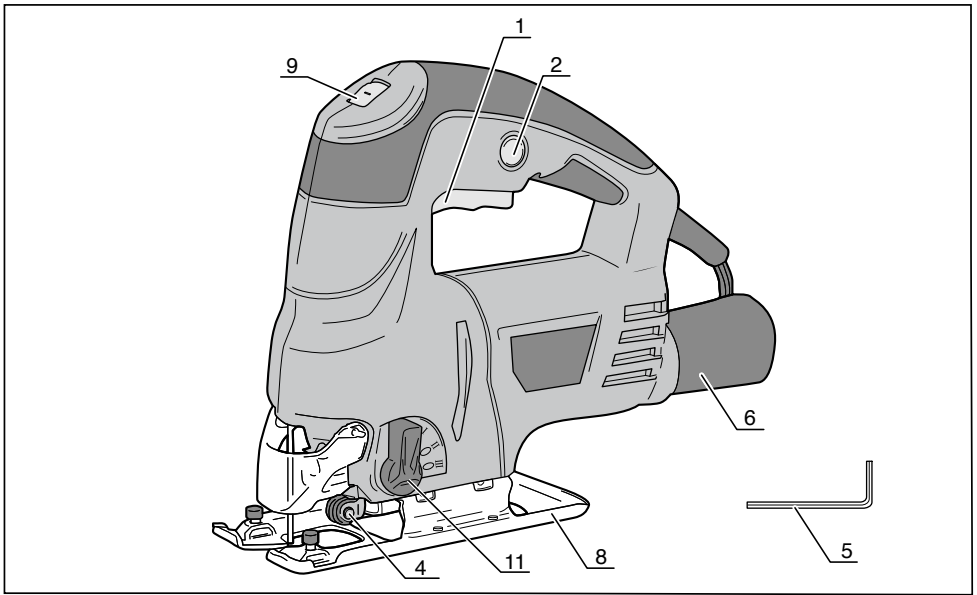

1

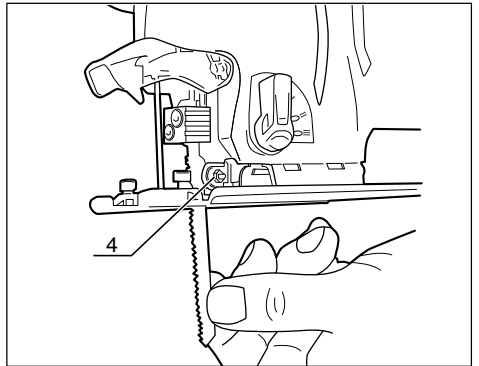

2

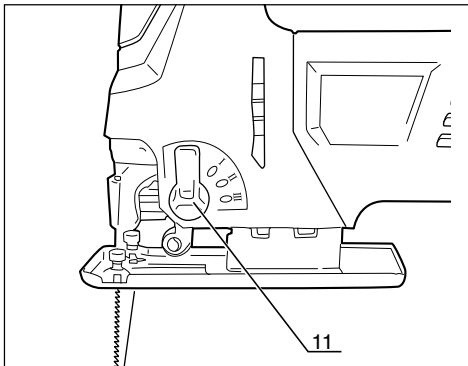

3

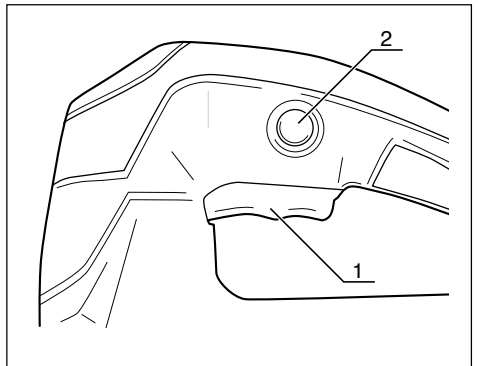

4

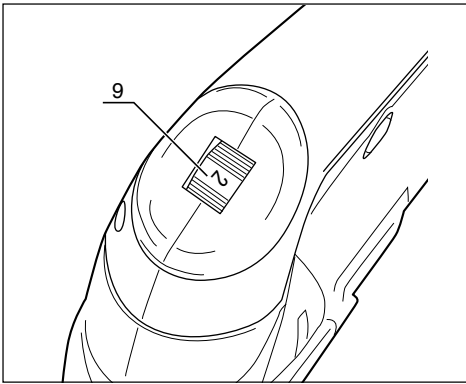

5

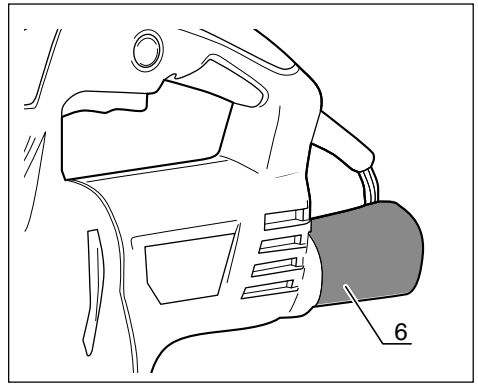

6

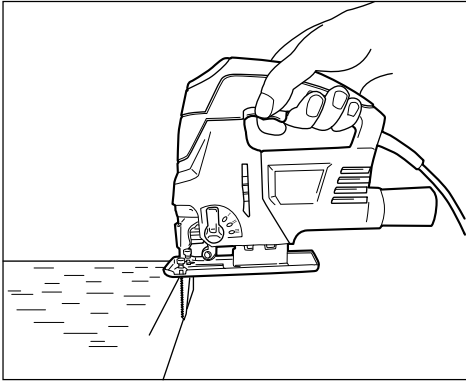

7

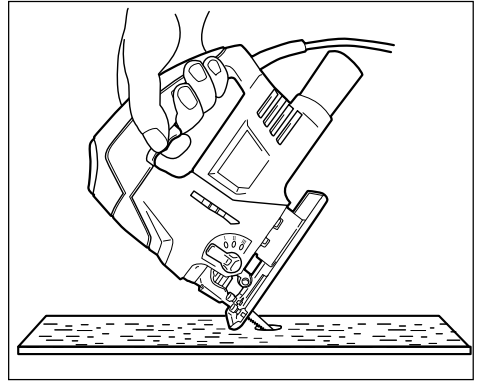

8

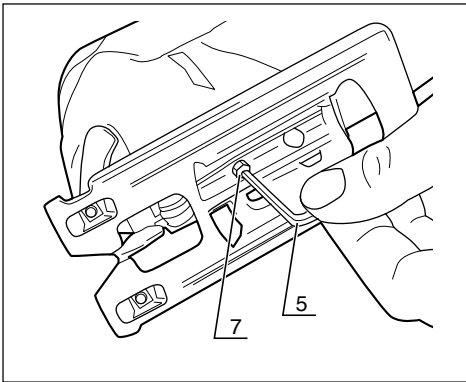

9

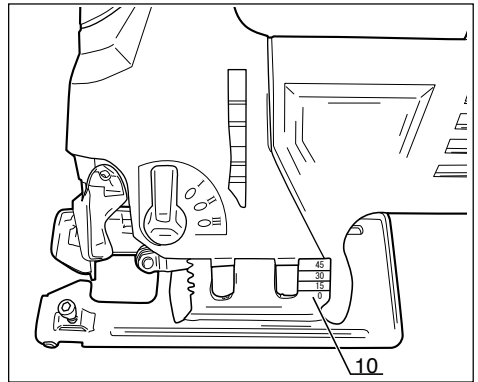

10



## THANK YOU FOR BUYING A RYOBI PRODUCT.

To ensure your safety and satisfaction, carefully read through this OWNER'S MANUAL before using the product.

### General Safety Rules

**WARNING!** Read all instructions. Failure to follow all instructions listed below may result in electric shock, fire and/or serious injury. The term "power tool" in all of the warnings listed below refers to your mains-operated (corded) power tool or battery-operated (cordless) power tool.

### SAVE THESE INSTRUCTIONS

#### 1) Work area

- a) **Keep work area clean and well lit.** Cluttered and dark areas invite accidents.
- b) **Do not operate power tools in explosive atmospheres, such as in the presence of flammable liquids, gases or dust.** Power tools create sparks which may ignite the dust or fumes.
- c) **Keep children and bystanders away while operating a power tool.** Distractions can cause you to lose control.

#### 2) Electrical safety

- a) **Power tool plugs must match the outlet. Never modify the plug in any way. Do not use any adapter plugs with earthed (grounded) power tools.** Unmodified plugs and matching outlets will reduce risk of electric shock.
- b) **Avoid body contact with earthed or grounded surfaces such as pipes, radiators, ranges and refrigerators.** There is an increased risk of electric shock if your body is earthed or grounded.
- c) **Do not expose power tools to rain or wet conditions.** Water entering a power tool will increase the risk of electric shock.
- d) **Do not abuse the cord. Never use the cord for carrying, pulling or unplugging the power tool. Keep cord away from heat, oil, sharp edges or moving parts.** Damaged or entangled cords increase the risk of electric shock.
- e) **When operating a power tool outdoors, use an extension cord suitable for outdoor use.** Use of a cord suitable for outdoor use reduces the risk of electric shock.

#### 3) Personal safety

- a) **Stay alert, watch what you are doing and use common sense when operating a power tool. Do not use a power tool while you are tired or under the influence of drugs, alcohol or medication.** A moment of inattention while operating power tools may result in serious personal injury.
- b) **Use safety equipment. Always wear eye protection.** Safety equipment such as dust mask, non-skid safety shoes, hard hat, or hearing protection used for appropriate conditions will reduce personal injuries.
- c) **Avoid accidental starting. Ensure the switch is in the off-position before plugging in.** Carrying power tools with your finger on the switch or plugging in power tools that have the switch on invites accidents.
- d) **Remove any adjusting key or wrench before turning the power tool on.** A wrench or a key left attached to a rotating part of the power tool may result in personal injury.
- e) **Do not overreach. Keep proper footing and balance at all times.** This enables better control of the power tool in unexpected situations.
- f) **Dress properly. Do not wear loose clothing or jewellery. Keep your hair, clothing and gloves away from moving parts.** Loose clothes, jewellery or long hair can be caught in moving parts.
- g) **If devices are provided for the connection of dust extraction and collection facilities, ensure these are connected and properly used.** Use of these devices can reduce dust-related hazards.

#### 4) Power tool use and care

- a) **Do not force the power tool. Use the correct power tool for your application.** The correct power tool will do the job better and safer at the rate for which it was designed.
- b) **Do not use the power tool if the switch does not turn it on and off.** Any power tool that cannot be controlled with the switch is dangerous and must be repaired.
- c) **Disconnect the plug from the power source and/or the battery pack from the power tool before making any adjustments, changing accessories, or storing power tools.** Such preventive safety measures reduce the risk of starting the power tool accidentally.
- d) **Store idle power tools out of the reach of children and do not allow persons unfamiliar with the power tool or these instructions to operate the power tool.** Power tools are dangerous in the hands of untrained users.
- e) **Maintain power tools. Check for misalignment or binding of moving parts, breakage of parts and any other condition that may affect the power tools operation. If damaged, have the power tool repaired before use.** Many accidents are caused by poorly maintained power tools.
- f) **Keep cutting tools sharp and clean.** Properly maintained cutting tools with sharp cutting edges are less likely to bind and are easier to control.
- g) **Use the power tool, accessories and tool bits etc., in accordance with these instructions and in the manner intended for the particular type of power tool, taking into account the working conditions and the work to be performed.** Use of the power tool for operations different from those intended could result in a hazardous situation.

#### 5) Service

- a) **Have your power tool serviced by a qualified repair person using only identical replacement parts.** This will ensure that the safety of the power tool is maintained.

### JIG SAW SAFETY PRECAUTIONS

1. Hold power tool by insulated gripping surfaces, when performing an operation where the cutting accessory may contact hidden wiring or its own cord. Cutting accessory contacting a "live" wire may make exposed metal parts of the power tool "live" and could give the operator an electric shock.
2. Use blades suitable for the material to be cut for efficient and safe operation. Make sure the saw blade is tightly secured, as described in the operation instructions.
3. Excessive pressure and bending while cutting may break the blade.
4. Cutting with the body of the tool fixed in a vice is very dangerous.
5. It is extremely dangerous to point the cutting surface towards any person.

### INSTRUCTIONS FOR SAFE HANDLING

1. Make sure that the tool is only connected to the voltage marked on the name plate.
2. Never use the tool if its cover or any bolts are missing. If the cover or bolts have been removed, replace them prior to use. Maintain all parts in good working order.
3. Always secure tools when working in elevated positions.
4. Never touch the blade, drill bit, grinding wheel or other moving parts during use.
5. Never start a tool when its rotating component is in contact with the workpiece.
6. Never lay a tool down before its moving parts have come to a complete stop.
7. **ACCESSORIES** : The use of accessories or attachments other than those recommended in these instructions might present a hazard.
8. **REPLACEMENT PARTS** : When servicing use only identical replacement parts.



## DESCRIPTION

1. Trigger
2. Lock-on button
3. Hex. socket head bolt
4. Roller guide
5. Hex. key wrench
6. Dust nozzle
7. Hex. socket head bolt
8. Base
9. Speed control dial
10. Angle scale
11. Selector lever

## SPECIFICATIONS

### Cutting capacities

In wood	65 mm
In steel	6 mm

Input	650 W
Strokes per minute	800 - 3,000 min <sup>-1</sup>
Overall length	215 mm X 200 mm X 70 mm
Net weight	1.8 kg

\* Be sure to check the rating label on the product, because the voltage is subject to change depending on the area in which the product is to be used.

## STANDARD ACCESSORIES

Jig saw blade, Hex. key wrench, Dust nozzle

## APPLICATIONS

(Use only for the purposes listed below.)

1. Cutting wood, resin boards and thin metal sheets.

## BLADE INSTALLATION (Fig. 1, 2)

### BE SURE TO DISCONNECT THE PLUG FROM THE POWER SOURCE BEFORE INSTALLING THE BLADE.

1. Loosen the hex. socket head bolts (3) by using the hex. key wrench (5).
2. Insert the blade completely into the spindle slot.
3. Tighten the hex. socket head bolts.

The hex. key wrench is stored in the holder on the cord-strain reliever. When not using the hex. key wrench, store it in the designated place.

### NOTE!

Check that the back of the jig saw blade enters the groove of the roller guide (4).

## ORBITAL ACTION (Fig. 3)

To obtain the best cutting action with various types of material, it is necessary to adjust the orbital action of the saw blade. This tool has a selector lever (11) on the side of the housing. Selections range from 0 for straight reciprocating blade action to III for largest orbit of the blade.

When cutting into wood and plastic or other soft materials, a large swing is required, i.e. position I, II or III. For steel and similar hard materials, the cutting action should not be so great, so position 0 should be used.

However, if a sharp and precise cutting surface is required for soft materials, then position 0 may also be used.

It is also intended for thin materials, as well as for knife or rasp work.

## SWITCH (Fig. 4, 5)

This tool is started and stopped by squeezing and releasing the trigger (1).

For continuous operation, press the lock-on button (2) while the trigger is squeezed. Depress the trigger again to release the lock.

This tool operates at speeds in the range of 800 – 3,000min<sup>-1</sup>. The speed control dial (9) permits adjustments while the tool is running and allows operation at the desired speed.

The general rules for cutting speed apply: the harder the material (steel), the lower the speed: the softer the material (wood), the higher the speed.

## DUST NOZZLE (Fig. 6)

While operating the tool, the dust nozzle (6) should be connected to a vacuum cleaner.

(The dust nozzle can be connected to a vacuum cleaner with a hose outer diameter of 34.5mm.)

## OPERATION

### NEVER COVER THE AIR VENTS SINCE THEY MUST ALWAYS BE OPEN FOR PROPER MOTOR COOLING.

### STARTING (Fig. 7)

For accurate cutting, hold the tool at right angles to the work. Hold the base of the tool in firm contact with the work.

### ARC CUTTING

In cases of small circle or arc cutting, use a lower cutting speed than for ordinary straight cutting.

### NOTE!

Too much pressure may break the blade when cutting in a circular motion.

### METAL CUTTING

Protective glasses should be used to protect the operator's eyes. Cutting oil or emulsion for steel, and turbine oil for non-metallic materials like aluminum should be used.

### CENTER CUTTING (Fig. 8)

To cut in the center of a board, rest the base of the tool on the board as shown in fig. 7, so that the blade does not touch it. Then turn the switch on and slowly lower the moving blade against the board.

For materials other than wood, a starting hole must be drilled first.

### BEVEL CUTTING (Fig. 9, 10)

Loosen the hex. socket head bolt (7) at the bottom of the base by using the hex. key wrench (5). Next align the bottom line of the housing to the angle scale (10) on the base plate, and then fasten the hex. socket head bolt firmly. Bevel cutting of 0 - 45° can be achieved easily.

## MAINTENANCE

After use, check the tool to make sure that it is in top condition. It is recommended that you take this tool to a Ryobi Authorized Service Center for a through cleaning and lubrication at least once a year.

### DO NOT MAKE ANY ADJUSTMENTS WHILE THE MOTOR IS IN MOTION.

### ALWAYS DISCONNECT THE POWER CORD FROM THE RECEPTACLE BEFORE CHANGING REMOVABLE OR EXPENDABLE PARTS (BLADE, BIT, SANDING PAPER ETC.), LUBRICATING OR WORKING ON THE UNIT.

### WARNING!

To ensure safety and reliability, all repairs should be performed by an AUTHORIZED SERVICE CENTER or other QUALIFIED SERVICE ORGANIZATION.

— NOTE —

— NOTE —

## RYOBI POWER EQUIPMENT WARRANTY

Subject to the warranty conditions below, this RYOBI tool (hereinafter called "the Product"), is warranted by Ryobi (herein called "the Company") to be free from defects in material or workmanship for a period of 24 months from the date of original purchase covering both parts and labour. Under the terms of this warranty, the repair or replacement of any part shall be the opinion of the Company or its authorised agent. Should service become necessary during the warranty period, the owner should contact the authorised Ryobi retailer from whom the product was purchased, or the nearest Company branch office. In order to obtain warranty service, the owner must include the Sales Docket and Warranty Certificate to confirm date of purchase. This Product is sold by the dealer or agent as principal and the dealer has no authority from the Company to give any additional warranty or guarantee on the Company's behalf except as herein contained or herein referred to.

### Warranty Conditions

This warranty only applies provided that the Product has been used in accordance with the manufacturer's recommendations under normal use and reasonable care (in the opinion of the Company) and such warranty does not cover consumable components, damage, malfunction or failure resulting from

misuse, neglect, abuse, or used for a purpose for which it was not designed, or is not suited and no repairs, alterations or modifications have been attempted by other than an Authorised Service Agent. This guarantee will not apply if the tool is damaged by accident or if repairs arise from normal wear and tear.

Accessories such as bits, blades, sanding discs, cutting lines, etc., are excluded from this guarantee. Normal consumable parts, such as carbon brushes, bearings, chucks, cord assembly's, spark plugs, recoil pulleys and bump head assembly's are specifically excluded from this guarantee.

The Company accepts no additional liability pursuant to this warranty for the costs of traveling or transportation of the Product or parts to and from the service dealer or agent - which costs are not included in the warranty.

Nothing herein shall have the effect of excluding, restricting or modifying any conditions, warranty, right or liability imposed, to the extent only that such exclusion, restriction or modification would render any term herein void.



**STEVENS & CO (Pty) Ltd**

604, 16th Street, Randjespark  
Midrand, South Africa

P O Box 4059  
HALFWAY HOUSE  
1685, South Africa

Tel: +27 (11) 357-9600

Fax: +27 (11) 805-5541

email: [stevens@ryobi.co.za](mailto:stevens@ryobi.co.za)

### THIS WARRANTY FORM SHOULD BE RETAINED BY THE CUSTOMER AT ALL TIMES.

For your record and to assist in establishing date of purchase (necessary for in-warranty service), please keep your purchase docket and this form, completed with the following particulars.

PURCHASED FROM:.....

ADDRESS OF DEALER:.....

DATE:..... MODEL NO..... SERIAL NO.....

Present this form with your Purchase Docket when Warranty Service is required.